



innkeeper 1rx™

Digital Hybrid



User Guide

Welcome

Thank You

Thank you for purchasing a JK Audio innkeeper 1rx Digital Hybrid. Please read this guide for instructions on setting up and using your new product.

Getting Assistance

If you have technical or application questions:

In the US & Canada, call us toll free at: **800-552-8346**

All other countries dial: **815-786-2929** (M-F 8:30-5:00pm Central Time Zone)

Email us at: support@jkaudio.com

Or, check out our FAQ section for answers to common questions.

Limited Warranty

The innkeeper 1rx is covered by a 2 year warranty to be free from defective workmanship and materials. To obtain service, contact JK Audio by phone or email for return authorization. Once authorized, you will carefully pack and ship the faulty product and all accessories to us. You will pay for shipping to us and we will pay for return back to you.

This warranty does not cover damages due to accident, weather, fire, flood, earthquake, misuse, unauthorized repairs or modifications, or damages occurred in shipping, only defective workmanship or materials.

There are no expressed or implied warranties which extend beyond the warranty here made.

Warnings & Safety Precautions

- Read and keep these instructions.
- Heed all warnings.
- Follow all instructions.
- Clean only with a soft dry cloth.
- Do not install near any heat sources such as radiators, heat registers, stoves, or other apparatus (including amplifiers) that produce heat.
- Do not defeat the safety purpose of the three-prong grounding type plug. If the provided plug does not fit into your outlet, consult an electrician for replacement of the obsolete outlet.
- Do not use this unit if the electrical power cord is frayed or broken. The power cord should be routed so that it is not likely to be walked on or pinched by items placed upon or against it.
- To reduce the risk of fire or electric shock, do not expose this apparatus to rain or moisture.
- Refer all servicing to qualified service personnel.

Overview	1
Getting to know your innkeeper 1rx	
2 Controls & Indicators	2
4 Inputs & Outputs	
Getting Connected	6
Operation	8
Configuration	9
Optional Remote Control	11
Serial Port Interface	12
FAQs	13
Technical Information	14

Features

Features

16 bit DSP Technology

Auto-Answer (Switchable On/Off)

Proprietary Auto Null Algorithm
(50 dB null)

AGC, Ducking, Presence

1 kHz Tone Generator

Send XLR Line Input

Mic/Line Switch

Caller XLR Line Output

Mix Out XLR Line Output

Front Panel 1/4" Headphone Jack

Remote Control via Screw Terminals
or RS-232

RIU-IP Remote IP Interface

Monitor Speaker Terminals

Send and Caller Signal Level LEDs

Send and Caller Volume Controls

What's in the Box?

Detachable North American
Power Cord

CN081 Serial Port Cord

RJ11 Phone Cord

Introducing the innkeeper 1rx™

innkeeper 1rx will allow you to send and receive audio over analog telephone lines. While this may seem like a simple task that any telephone can do, the challenge is getting the best quality audio from such a miserable audio path.

What is a Digital Hybrid?

The innkeeper 1rx digital hybrid connects audio signals to a standard analog telephone line without the variations in quality found with analog hybrids. The main function of a hybrid is to bring in the caller's voice from the phone line as clear and clean as possible. In the real world, when you send your voice down the telephone line it has a tendency to bleed over into the caller's audio. The hybrid must adapt to the phone line in order to properly separate transmit and receive audio. We use a 16 bit DSP (Digital Signal Processor) to continuously monitor the phone line and local audio signals to deliver excellent trans-hybrid loss, also known as separation. Our dual-convergence algorithm can achieve excellent separation, typically exceeding 50 dB.

Ready to go?

The innkeeper 1rx controls and connectors are clearly marked and ready for operation. If this is your first exposure to a hybrid, we suggest that you read the entire manual to allow you to take advantage of all these features.

Any Questions?

Before you pick up the phone... Please thumb through the rest of this manual. You might find those deep technical questions are covered on later pages.

Getting to Know Your innkeeper 1rx

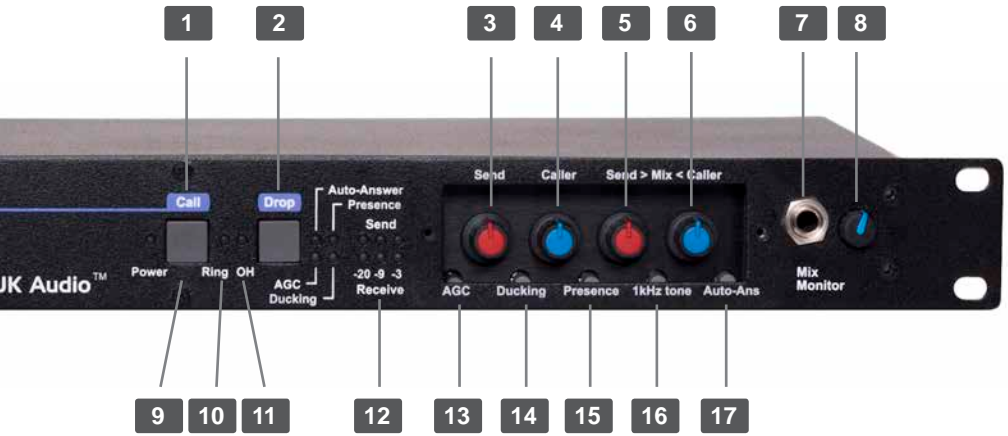

Controls & Indicators

1. Call Button

Takes the line off-hook; press this button to answer a call or you can direct a call from your aux phone through the hybrid.

2. Drop Button

Press this button to drop (hang up) a call.

3. Send Level

Adjusts the signal that you are sending down the telephone line.

4. Caller Level

Adjusts the level of the incoming caller's audio as it is going out the output jacks. If the incoming caller level is too high and peaking the red -3 dB LED, you may need to change the setting of an internal jumper. Please see Optional Jumper Settings on **page 9**.

5. Send-to-Mix Level

Adjust the level of your audio that will be sent to the <Mix Out> jack.

6. Caller-to-Mix Level

Adjust the level of caller audio that will be sent to the <Mix Out> jack.

7. Headphones

The stereo headphone jack contains the signal you have created with the <Send-to-Mix> and <Caller-to-Mix> level controls. Both left and right channels get the same signal.

Indicators Cont'd

8. **Mix Monitor**

Adjusts the mix signal level sent to the headphone and rear panel speaker terminals.

9. **Power LED**

Lit when unit is plugged in and receiving power.

10. **Ring LED**

Flickers when you have an incoming call.

11. **OH LED**

Lit when you are on line with a call (off-hook).

12. **Signal LEDs**

Send LEDs represent the signal level going out to the telephone line. Receive LEDs represent the signal level coming from the phone line, after the DSP.

13. **AGC - Automatic Gain Control**

When enabled, automatically adjusts the gain of caller audio so all callers are received at an average level.

14. **Caller Ducking**

When enabled, innkeeper 1rx lowers the caller's audio level by 9 dB when local audio is present.

15. **Presence**

When enabled, this feature boosts the low end of the caller audio signal. Presence is added to the caller audio signal only.

16. **1 kHz Tone Generator**

Press button once to send a full scale 0 dB, maximum output level 1kHz tone down the phone line. Press again to send this signal out the Caller jack. Press a third time to turn off.

17. **Auto-Answer**

When enabled, innkeeper automatically answers an incoming call and then disconnects after the caller hangs up. Auto answer will occur on the first ring.

Getting to Know Your innkeeper 1rx



Inputs & Outputs

1. Phone Line

Connect to a standard, single line, analog telephone line.

2. Aux Phone

Connect a single line analog telephone for call setup / dialing, or producer call screening.

3. Caller Output

Male balanced XLR line-level output contains only the callers voice.

4. Mix Output

Male balanced XLR line-level output contains a mix of send and receive audio determined by the **<Send-to-Mix>** and **<Caller-to-Mix>** level controls.

5. Mic / Line switch

Sets the front end sensitivity of the Send XLR jack. Set to **<Mic>** if you intend to connect a dynamic microphone directly to the **<Send>** jack. Set to **<Line>** if you are connecting to the output of a mixer. This device does not provide phantom power for a condenser type microphone.

6. Send Input

Female balanced XLR input for signals going into the phone line. Mic or line level input.

Inputs & Outputs Cont'd

7. Remote Control Jack

10 pin RJ-50 modular jack for connection to:

- A. RS-232 Cable (Included)
- B. JK Audio RIU-IP Remote Interface. See **page 11**.
- C. JK Audio Guest Module 1 Remote Keypad. See **page 11**.
- D. JK Audio Concierge Switch Core

8. Remote Terminals

Screw terminals provide connections for a small speaker, remote LEDs, tape recorder control, or console call control switches.

1. Speaker (+)	Minimum 8 ohms, 1 watt max
2. Speaker (-)	Use together with terminal 1
3. Ring LED	Supplies +4.3 VDC, 40 mA pulse signal during incoming ring cycles.
4. Chassis Ground	
5. OH LED	Supplies +4.3 VDC, 40 mA steady signal during an active call.
6. Call (NO)	Pull this pin to ground momentarily to simulate pressing the <Call> button.
7. Drop (NO)	Pull this pin to ground momentarily to simulate pressing the <Drop> button.
8. Reserved	

9. Power Jack

Universal AC power input for 100-240 Volt, 50-60 Hz supply current.

Getting Connected

Setting Up

1. Connect the supplied RJ-11 phone line cable between the jack marked **<Line>** and your wall jack. Be sure this jack supports standard single line analog telephone operation.
2. Connect to your mixer using the *Mix-Minus* method. See Figure 7a. *A mix-minus signal is an audio signal that contains a mix of your local microphones plus any other audio, minus the Caller's own voice. Sending the Caller's audio back to the innkeeper 1rx will cause an echo, or feedback.*
 1. Connect a microphone or mixing console output XLR cable to the **<Send>** jack on the innkeeper. Be sure to set the innkeeper **<Mic/Line>** switch to the proper position for your application.
 2. Connect the **<Caller>** jack to a line level input on your mixing console. For whichever input channel you have the **<Caller>** connected to on the mixer, turn the corresponding **<Aux>** control to minimum. All other **<Aux>** controls should be set for audio sent to the phone line. Each **<Aux Send>** bus is completely separate from all other outputs, so these Aux controls will not affect what is heard on the Main outputs or on any other Aux buses. We recommend using an **<Aux Send>** bus that is pre-fader, so you can use the fader controls to set the levels of each channel to the main output without affecting what is sent to the phone line. If your mixer does not have an **<Aux Send>** bus, you can use **<Pan>** controls with the Left and Right outputs. Pan all the microphones, etc. to the Left output and pan the Caller to the Right output. Then connect only the **<Left>** output to the innkeeper 1rx **<Send>**. Or, you may use an external Mix-Minus box that will create this signal for you.
3. Connect the supplied AC power cord to the back of the innkeeper and then to an AC power outlet.

Your innkeeper 1rx is now ready to take calls. You may want to connect an auxiliary telephone to the innkeeper **<Phone>** jack so you can dial out and set up calls, or use the **<Auto-Answer>** feature to answer incoming calls.

Place a test call to a quiet location. Set the **<Send>** level control so that while you are speaking into the microphone, the Send LEDs on the hybrid light the -20 dB green LED consistently and flash the -9 dB green LED. If you flash the -3 dB red LED, lower the level. Set the **<Caller>** control for good recording level of the caller audio at the output jack.

Figure 7a



GUEST MODULE 1



Operation

Send Signal Level

The **<Send>** LEDs display the signal level as it goes out to the phone line. The goal is to drive the phone line at high enough levels to avoid phone line noise, but not so loud as to cause excessive clipping. Adjust the **<Send>** level control until you see occasional flashes of the second green LED (-9dB) and very rarely any flashes of the red -3dB peak Send LED. These flashes should occur only during loud speech bursts. If the red LED stays lit for extended periods you can assume that much of your speech is being clipped or distorted. In this case you should lower the **<Send>** volume control.

Receive Signal Level

The **<Receive>** LEDs display the signal coming from the phone line and out of the DSP. The **<Caller>** level control does not change what you see on these LEDs. Adjust the **<Caller>** level control to give you the best signal at your equipment.

AGC

When the Automatic Gain Control **<AGC>** is used, innkeeper 1rx automatically adjusts the **<Caller>** level to maintain acceptable levels between calls. In this way an unusually loud caller will be similar in level to the unusually soft caller.

Caller Ducking

The Caller **<Ducking>** option lowers the level of the Caller's audio by 9 dB when local audio is present. This is a good way to regulate those obnoxious callers when the talent is speaking.

Presence

The **<Presence>** feature is a custom digital filter that boosts low frequencies in the 120Hz to 500Hz region to compensate for losses in the telephone network. This is a single ended algorithm that treats only the Caller signal before it leaves the digital hybrid. You may notice that it has more of an effect on low pitched, or deeper voices.

1 kHz Tone Generator

The **<1 kHz tone>** generator is a three-state button used for setting levels on your other equipment. It is not used to null the phone line. When pressed once a full scale 0dB maximum output level signal is sent down the phone line. This will allow you to calibrate levels at the other end of the call. When pressed again, this same signal is sent to the **<Caller>** output only. This will allow you to calibrate the signal level at your console. The tone generator is disabled when pressed a third time.

Auto-Answer

The **<Auto-Answer>** feature will answer on the first ring. When **<Auto-Answer>** is enabled, you can still make calls manually using the **<Call>** button. When finished, you can either drop the call manually or allow the call to Auto-Disconnect. innkeeper will look for a CPC (Calling-Party-Control) disconnect signal or ROH (Receiver-Off-Hook) message from the phone company to determine when a call has disconnected. This can take up to a minute.

Auxiliary Telephone

innkeeper 1rx does not disconnect the auxiliary telephone when you press the **<Call>** button. You can use an auxiliary phone to place or screen a call and then place it on hold. When you are ready to take the call on innkeeper 1rx, simply press the **<Call>** button. Your telephone will automatically release the hold. If you need to take the call back on the aux telephone, simply pick up the telephone handset before the innkeeper 1rx **<Drop>** button is pressed. If you prefer to disconnect the aux phone when the hybrid takes a call, please refer to the Optional Jumper Settings section below for Jumpers 2 and 3.

Optional Jumper Settings

MUST BE PERFORMED BY QUALIFIED SERVICE PERSONNEL. To change the setting of an internal jumper, disconnect power from the hybrid before removing the cover of the innkeeper 1rx. The default jumper position is **Closed** (covering both pins). To **Open** the jumper, remove the jumper or cover just one pin.



WARNING! The AC cable must be unplugged from the back of the innkeeper any time the case is opened. Failure to follow these instructions could result in injury or death.

Jumper 1: Attenuation

If the incoming caller level is too high and peaking the red -3 dB LED, change Jumper 1 to the **Open** position. This will provide 6 dB attenuation of the incoming audio signal. This does not affect transmit level.

REPLACE AND SECURE THE COVER BEFORE RECONNECTING THE POWER CORD.

Jumpers 2 & 3: Auxiliary Telephone

In the factory default **Closed** position, the **<Line>** jack and **<Phone>** jacks are **Bridged**.

In the optional **Open** position, the jacks are **Switched**. This means that when the **<Call>** button is pressed, any phones connected to the phone jack of the innkeeper are disconnected.

REPLACE AND SECURE THE COVER BEFORE RECONNECTING THE POWER CORD.

Configuration

Custom Dry Line Installation

Innkeeper 1rx was designed to work on standard (wet) telephone lines as well as on custom PBX (dry) lines. Dry line installation is always a custom configuration and requires substantial telephone system knowledge. These installations are found in radio and television studios for both PBX and intercom applications.

Wet lines are typical tip / ring telephone lines that carry ring voltage, talk battery, and full duplex, balanced audio over two wires to an analog telephone. Dry lines carry the balanced, full duplex audio but without the ring voltage or talk battery. Innkeeper does allow dry line operation with a few limitations:

- If talk battery is not present when the **<Call>** button is pressed, a dry line is assumed.
- If talk battery suddenly appears during a dry line call, it becomes a wet line call, and auto-disconnect will occur when a disconnect signal occurs, or if talk battery disappears.
- Auto-answer does not work on a dry line.
- The aux telephone jack will not support an analog telephone during a dry line call.

Optional Remote Control Devices

RIU-IP (Sold Separately)

This remote control interface was designed for use with innkeeper 1rx as well as JK Audio innkeeper 2 and innkeeper 4 digital hybrids. This unit contains a web server which allows the user to send and receive control data through their web browser. RIU-IP can be connected to the user's computer NIC card for direct control, to a switch or hub for network control, or to an Ethernet port with internet access for control from anywhere in the world. **Product sold separately.**

RIU-IP Features and capabilities when used with innkeeper 1rx:

- RJ-45 Ethernet port
- RS-232 remote control port with simple ASCII protocol
- No external power required
- Indication of incoming ring
- On-Hook and Off-Hook
- Confirmation of Off-Hook or On-Hook transition
- Place call on hold or release hold.
- Dial (number) (line).
- Auto-Answer: On / Off
- Test Tone: Start / Stop
- Presence: On / Off
- Caller Ducking: On / Off
- Automatic Gain Control: On / Off

Guest Module 1 (Sold Separately)

This convenient device gives you remote access to the on-hook/offhook and dial features of the innkeeper 1rx. The **<Call>** button will flicker when a call comes in and will stay lit while a call is present. When you dial out using the Guest Module 1 keypad, the tones are sent directly down the phone line, and do not come back blasting in your ear. **Product sold separately.**

Guest Module 1 Features:

- Ring and Call LED
- Call and Drop Buttons
- DTMF Keypad
- Keypad Disable Switch
- Remote Powered



ASCII Command Remote Control Cont'd

Command	Name	n Parameter / Description
/Dls	Dial	Take line off-hook and dial phone number. ';' Each comma will insert a one second pause in the digit string (Max Delay = 5 sec). '!' To insert a flash hook in the digit string.
The following unsolicited responses will inform you of changes in call state.		
ONHK		The line has been disconnected.
OFFHK		The line is off-hook.
RING		Incoming call.

FAQs

1. Does the innkeeper 1rx send a burst or beep down the phone line at the beginning of each call like our current hybrid?

No. Innkeeper 1x uses the actual transmit signal to evaluate the phone line and tune its algorithm. As you begin to speak, innkeeper 1x is hard at work canceling your voice from the Caller Output jack. Within milliseconds your voice is reduced into the noise floor.

2. Will your innkeeper 1rx provide phantom power for my condenser microphone?

No, our devices will not provide phantom power. If you plan to connect your microphone directly to an innkeeper 1x, you should use a dynamic mic.

3. Are there more ASCII commands I can send through the serial cable or can I add my own?

The complete list of currently acceptable commands is listed on page 12.

4. Where is the software to control the serial port?

There is no software provided with the innkeeper 1rx. You will provide your own terminal emulator, such as Hyper-Terminal.

5. How do I know what firmware my innkeeper 1rx is running on and how can I update it?

Contact support@jkaudio.com for possible firmware updates.

Technical Information

Block Diagram

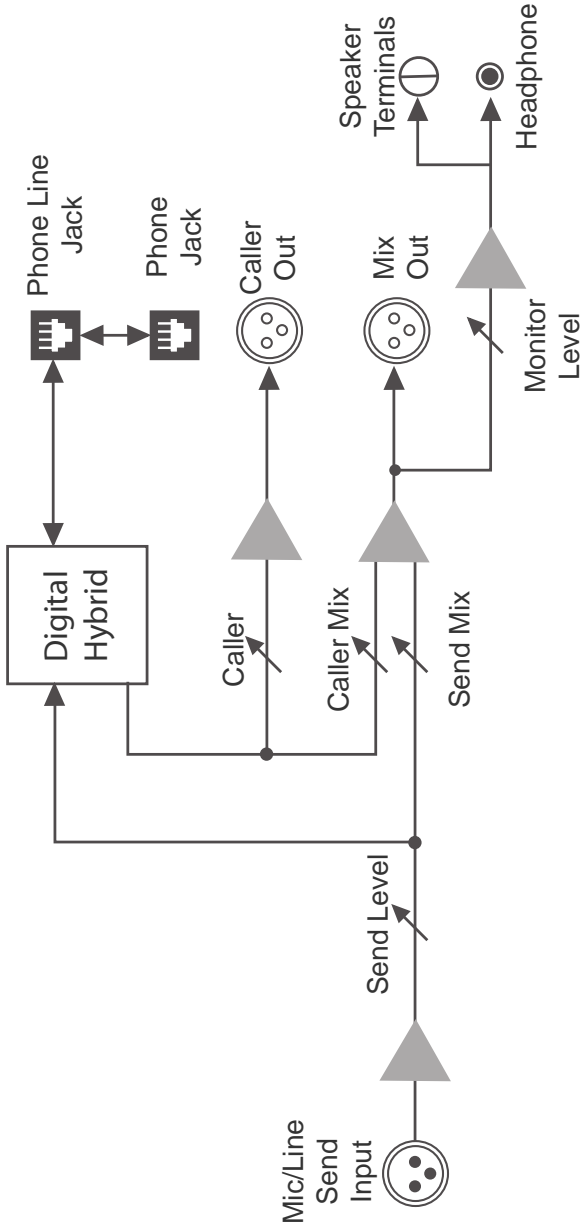

Specifications

Input	Impedance / Level
Balanced Female XLR:	1k ohms / 15 mV RMS; -34 dBu nom.; Mic/Line Pad Switch = +6 dBu max
Output	
Balanced Male XLR:	200 ohms / 500 mV RMS; -4 dBu nom.; +14 dBu max; Caller Only
1/4" Stereo Headphone:	8 ohms / 250 mW per channel
Speaker	Screw Terminals, 8 ohms, 1 watt
Misc	
Phone Line:	RJ11C
Aux Phone:	RJ11C
Ringer:	0.8B REN
Isolation:	1500 VAC
Frequency Response:	Telephone Side 200 Hz-3.6 kHz ASCII RS-232 (DB9)
Remote Control:	Screw Terminal I/O IP Web Server (optional)
Recommended Operating Temperature:	-20°C to +40°C
Power:	120-240 VAC Power Supply
Size:	1.75" x 7.3" x 19" (4.5 x 18.6 x 48.3 cm)
Weight:	5.7 lbs (2.6 kg)

Declaration of Conformity

Declaration of Conformity

Manufacturer's Name: JK Audio, Inc.
Manufacturer's Address: 1311 E 6th Street
Sandwich, Illinois 60548 USA

Declares that the product:

Product Name: innkeeper 1rx Digital Hybrid
Model Numbers: innkeeper 1rx

Conforms to the following Product Specifications:

Safety: EN 60950 / AS/NZS 60950:2000
CAN/CSA-C22.2 No. 60950-01-03

ESD: EN 55024:1998; EN 61000-3-2; EN 61000-3-3

Emissions: EN 55022:1998
AS/NZS CISPR 22 (2002)
FCC Part 15, Subpart B
ICES-003

Telecom: AS/ACIF S002:2001
FCC CFR 47, Part 68

Declaration of Conformity

The product herewith complies with the requirements of the following Directives and carries the CE marking accordingly:

LVD 2006/95/EC (Safety)
R&TTE 1999/5/EC (Telecom)
EMC 89/336/EEC (EMC)
RoHS Directive 2002/95/EC

The Technical File containing supporting documentation is maintained at:

JK Audio, Inc (Corporate Headquarters)
Compliance Manager
1311 E 6th Street
Sandwich, Illinois 60548 USA
815-786-2929 phone
815-786-8502 fax

FCC Registration

FCC Registration

Your new JK Audio product has been registered with the Federal Communications Commission (FCC). This product complies with the standards in Part 68 of the FCC rules.

1. Connection and use with the nationwide telephone network

The FCC requires that you connect this telephone equipment to the national telephone network through a USOC RJ-11C modular telephone jack. This equipment may not be used with Party Line Service or Coin Telephone Lines. This equipment is hearing aid compatible.

2. Information for the telephone company

Upon request from your local telephone company, you are required to provide the following information:

- A. The "line" to which you will connect the telephone equipment (that is, your telephone number), and
- B. The telephone equipment's FCC registration number. This can be found on the bottom of your telephone equipment, and,
- C. The ringer equivalence number (REN) for this equipment. The REN is used to determine the quantity of devices which will be connected to the telephone line. Excessive RENs on the telephone line may result in the devices not ringing in response to an incoming call. In most, but not all areas, the sum of the RENs should not exceed 5.0. To be certain of the number of devices that may be connected to the line, as determined by the total RENs, contact the local telephone company.

3. Repair Instructions

If it is determined that your telephone equipment is malfunctioning, the FCC requires that it not be used and that it be unplugged from the modular outlet until the problem has been corrected. Repairs to this telephone equipment can only be made by the manufacturer or its authorized agents or by others who may be authorized by the FCC. For repair procedures, follow the instructions outlined under the warranty section of the manual.

4. Rights of the telephone company

If telephone equipment is causing harm to the network, the telephone company may temporarily discontinue your telephone service. If possible, they'll notify you before they interrupt service. If advanced notice isn't practical, you'll be notified as soon as possible. You'll be given the opportunity to correct the problem, and you'll be informed of your right to file a complaint with the FCC. Your telephone company may make changes in its facilities, equipment, operations or procedures that could affect the proper functioning of your JK Audio product. If such changes are planned, you'll be notified by your telephone company.

FCC Part 15 Subpart A Compliance

This equipment has been tested and found to comply with the limits for a Class A digital device, pursuant to Part 15 of the FCC Rules. These limits are designed to provide reasonable protection against harmful interference when the equipment is operated in a commercial environment. This equipment generates, uses, and can radiate radio frequency energy and, if not installed and used in accordance with the instruction manual, may cause harmful interference to radio communications. Operation of this equipment in a residential area is likely to cause harmful interference in which case the user will be required to correct the interference at his/her own expense.

Changes or modifications not expressly approved by JK Audio can void the user's authority to operate the equipment.

innkeeper 1rx™
Digital Hybrid



User Guide Version 7/17/18

JK Audio, Inc.
1311 E 6th St.
Sandwich, IL 60548
United States
Telephone: 815.786.2929
Toll Free: 1.800.jkaudio
Fax: 815.786.8502
www.jkaudio.com

© 2018 JK Audio, Inc. All rights reserved.

JK Audio