



THAT-2™

Telephone Handset Audio Tap

User Guide

JK Audio

Welcome

Thank You

Thank you for purchasing the JK Audio THAT-2™. Please read this guide for instructions on using it.

Getting Assistance

If you have technical or application questions:

In the US & Canada, call us toll free at: **800-552-8346**

All other countries dial: **815-786-2929**
(M-F 8:30-5:00pm Central Time Zone)

Email us at: support@jkaudio.com

Or, check out our FAQ section for answers to common questions.

Limited Warranty

THAT-2 is covered by a 2 year warranty to be free from defective workmanship and materials. To obtain service, contact JK Audio by phone or email for return authorization. Once authorized, you will carefully pack and ship the faulty product and all accessories to us. You will pay for shipping to us and we will pay for return back to you.

This warranty does not cover damages due to accident, weather, fire, flood, earthquake, misuse, unauthorized repairs or modifications, or damages occurred in shipping, only defective workmanship or materials.

There are no expressed or implied warranties which extend beyond the warranty here made.

Contents

Overview	1
Setup	3
Operation	4
FAQs	6
Technical Information	8

Note: While THAT-2 was designed to be very rugged and durable, it is not waterproof and care should be taken to keep the unit dry.

Features

Works with Analog, Digital, PBX, and ISDN Telephones

RCA Input & Output

XLR Input & Output

Input Level Control

Output Level Control

Switch Selects Between Carbon, Dynamic or Electret Handset Types

Passive Design. No Battery or AC Required

Introducing THAT-2

Connect THAT-2 between your telephone and handset for quick access to audio in and out of the telephone. The THAT-2 is used by radio stations to record and play sound bites, and by TV and film sound crews to get IFB dialog over phone lines.

Record (Line Output)

There are two output jacks on THAT-2. Both the white RCA phono jack on the front, and the male XLR jack carry the same signal. These mic level output jacks provide a mix of both sides of the conversation. In other words, whatever you send down the phone line will come back on these

jacks mixed with the audio from the other side of the call. This mix ratio is not adjustable, it is a function of the telephone, not our product. As it turns out, this is a suitable mix ratio for most applications.

Play (Line Input)

There are two input jacks on THAT-2. You can use either the red RCA phono jack on the front or the female XLR jack on the back. These are line level inputs for signals that you want to send down the phone line. These jacks can be connected to an audio output such as the headphone output jack on a tape recorder, the line output of a PC audio card, or the line output from a CD player or audio mixer.

Overview



Top View



Getting Connected

THAT-2 connects between the handset and the base of your telephone. Follow these simple steps:

1. Unplug the modular handset cord from your telephone base.
2. Using the black handset jumper cord that we have provided, connect the Telephone jack of THAT-2 to the handset jack on your telephone base.
3. Plug your handset cord, and handset, into the Handset jack on THAT-2.
4. Connect your audio equipment to the line input and output jacks on THAT-2.

Note: Not for use with telephones that have a keypad in the handset.

Operation

Handset Type Switch

The three position switch on the front of THAT-2 selects the type of microphone that is in the handset of your telephone. When you push the **Line In** button in, THAT-2 replaces the handset microphone signal with a circuit that must match the characteristics of the handset microphone.

The Handset Type switch can cover the main three microphone types, but keep in mind that there is no industry standard for microphone types or characteristics and therefore we cannot guarantee a perfect match with every telephone. There is no way to tell which type of mic is in your telephone handset. Simply use the position that sounds best without clipping or signal break-up. The balanced input XLR is wired:

A	B	C
Electret	Dynamic	Carbon

Note: Not all telephones are built alike so we cannot guarantee THAT-2 will work with every handset design available. We designed the interface to work with most popular designs.

Handset/ Line In Button

The **Handset / Line In** button selects which signal will be sent down the phone line; the handset microphone, or the line input jack.

Position: Out

Use the handset to speak and listen as you normally would. The sound that you hear on the handset is always available on the **From Phone** output jack.

Position: In

The handset mic is disconnected and the line input is connected to send audio signals down the line.

You can also use the **Handset / Line In** button to turn off the handset mic if you are listening to the line output signal over a loudspeaker. This will prevent feedback between the handset microphone and loudspeaker. In any case you can always listen over the handset receiver.

We designed this interface to work with most popular telephone designs. If a conflict arises it will typically be on the line input side. If you attempt to send voice band signals down the line input jack and the distant party complains that the level is too loud or severely distorted (clipping), try to lower the transmit signal on your audio equipment. If this does not help, discontinue use immediately.

FAQs

How do I use a microphone with the THAT-2?

THAT-2 needs a Line level signal to send audio down the phone line. You will either have to use a microphone pre-amplifier or a mic mixer.

When I try to send audio down the line it won't work.

Firstly, you must send a line level signal into the **Line Input** jack on THAT-2. Secondly, make sure the gray button is in the **In** position. This disables the handset mic and enables the audio input. Thirdly, check the **Handset Type** ABC switch.

Every time I press in the gray button I get a loud squeal and feedback. How do I fix this?

Try changing the setting of the **Handset Type** ABC switch. If the handset type is not set correctly you could get the feedback you are describing. Trial and error works best to find the right handset type but this info also may help.

A	B	C
Electret	Dynamic	Carbon

What is the gray pushbutton on THAT-2 used for?

The button is used to select which audio signal will be sent into the telephone.

Out: Handset Audio

In: Line Input

Keep in mind that you cannot send audio into the **Line Input** XLR/RCA jack and talk on the handset at the same time. However, any audio sent into the phone can be heard on the handset and is available on the XLR/RCA **From Phone** output jack at all times.

I have everything connected correctly. Why can't the caller hear me?

You cannot use the speakerphone function on your telephone during your recording. THAT-2 accesses the audio through the handset cord. With the speakerphone turned on, there is no audio going through the handset.

We're using THAT-2 to get caller audio to broadcast on our call in radio show. How do we get better sound quality?

THAT-2 was designed for only record and play applications. For better sound quality you should consider getting an Innkeeper digital hybrid.

Block Diagram

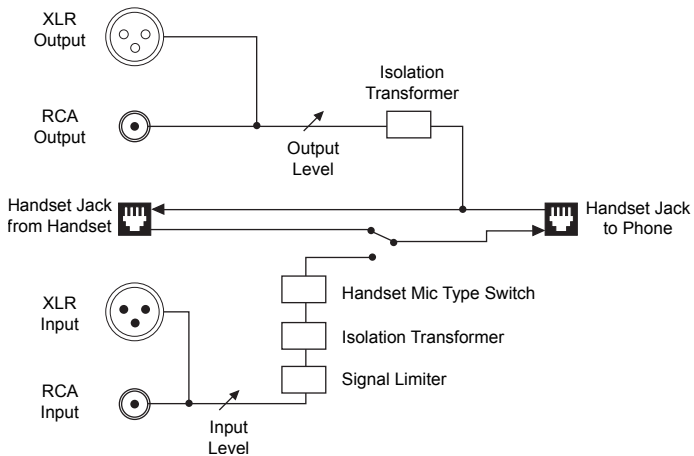

Specifications

Line Input

RCA (Unbalanced):	600-9000 ohms / 250 mV RMS (+12 dBu nom)
-------------------	---

Female XLR (Balanced):	600-9000 ohms / 250 mV RMS (+12 dBu nom)
------------------------	---

Output

RCA (Unbalanced):	0-2500 ohms 100 mV RMS (-18 dBu nom)
-------------------	---

Male XLR (Balanced):	0-2500 ohms 100 mV RMS (-18 dBu nom)
----------------------	---

Misc.

Handset Jack:	RJ-22
---------------	-------

Handset Type:	Electret, Dynamic, Carbon
---------------	---------------------------

Size:	4.5" x 3.2" x 1.3" (11.4 x 8.2 x 3.3 cm)
-------	--

Weight:	9 oz
---------	------

FCC Registration

Your new JK Audio product has been registered with the Federal Communications Commission (FCC). This product complies with the standards in Part 68 of the FCC rules.

1. Connection And Use With The Nationwide Telephone Network

The FCC requires that you connect this telephone equipment to the national telephone network through a USOC RJ-11C modular telephone jack. This equipment may not be used with Party Line Service or Coin Telephone Lines. This equipment is hearing aid compatible.

2. Information For The Telephone Company

Upon request from your local telephone company, you are required to provide the following information:

- a. The "line" to which you will connect the telephone equipment (that is, your telephone number), and
- b. The telephone equipment's FCC registration number. This can be found on the bottom of your telephone equipment, and,
- c. The ringer equivalence number (REN) for this equipment. The REN is used to determine the quantity of devices which will be connected to the telephone line. Excessive RENs on the telephone line may result in the devices not ringing in response to an incoming call. In most, but not all areas, the sum of the RENs should not exceed 5.0. To be certain of the number of devices that may be connected to the line, as determined by the total RENs, contact the local telephone company.

FCC Registration

3. Repair Instructions

If it is determined that your telephone equipment is malfunctioning, the FCC requires that it not be used and that it be unplugged from the modular outlet until the problem has been corrected. Repairs to this telephone equipment can only be made by the manufacturer or its authorized agents or by others who may be authorized by the FCC. For repair procedures, follow the instructions outlined under the warranty section of the manual.

4. Rights Of The Telephone Company

If telephone equipment is causing harm to the network, the telephone company may temporarily discontinue your telephone service. If possible, they'll notify you before they interrupt service. If advanced notice isn't practical, you'll be notified as soon as possible. You'll be given the opportunity to correct the problem, and you'll be informed of your right to file a complaint with the FCC. Your telephone company may make changes in its facilities, equipment, operations or procedures that could affect the proper functioning of your JK Audio product. If such changes are planned, you'll be notified by your telephone company.

THAT-2™

Telephone Handset Audio Tap



User Guide Version 9/8/16

JK Audio, Inc.

1311 E 6th St.

Sandwich, IL 60548

United States

Telephone: 815.786.2929

Toll Free: 1.800.jkaudio

Fax: 815.786.8502

www.jkaudio.com

© 2016 JK Audio, Inc. All rights reserved.

JK Audio