



# Inline Patch™ TELEPHONE AUDIO INTERFACE



## User Guide

# Welcome

## Thank You

Thank you for purchasing a JK Audio Inline Patch Analog Telephone Audio Interface. Please read this guide for instructions on setting up and using your new product.

## Getting Assistance

If you have technical or application questions:

In the US & Canada, call us toll free at: **800-552-8346**

All other countries dial: **815-786-2929** (M-F 8:30-5:00pm Central Time Zone)

Email us at: [support@jkaudio.com](mailto:support@jkaudio.com)

Or, check out our FAQ section for answers to common questions.

## Limited Warranty

The Inline Patch is covered by a 2 year warranty to be free from defective workmanship and materials. To obtain service, contact JK Audio by phone or email for return authorization. Once authorized, you will carefully pack and ship the faulty product and all accessories to us. You will pay for shipping to us and we will pay for return back to you.

This warranty does not cover damages due to accident, weather, fire, flood, earthquake, misuse, unauthorized repairs or modifications, or damages occurred in shipping, only defective workmanship or materials.

THERE ARE NO EXPRESSED OR IMPLIED WARRANTIES WHICH EXTEND BEYOND THE WARRANTY HERE MADE.

## Contents

Overview	1
Getting to know your Inline Patch™ 2 Controls & Indicators 3 Inputs & Outputs	2
Getting Connected	4
Operation	6
FAQs	7
Technical Information	8

# Features

## Features

---

Works with Analog Telephones  
including Cordless Telephones

---

XLR Input and Output Jacks

---

3.5mm Stereo Output  
Left Channel= Line  
Right Channel = Phone

---

3.5mm Mono Output

---

3.5mm Mono Line Input

---

3.5mm Jack for Remote  
On-Hook / Off-Hook

---

Front panel Separation control  
20 dB Nominal Separation of Phone Line  
Transmit / Receive Audio

---

### Introducing the Inline Patch™

This unique hybrid works with your telephone to give you more control over interview recording and playback.

The Inline Patch connects between the base of an analog or cordless telephone and the wall jack. You can continue to talk on the phone and get access to audio on both sides of the call. The unit's two back-to-back hybrids give you complete control of audio from both sides of the call. Audio input jacks let you mix sound bytes or music into your conversation. One stereo output jack provides your voice on one channel and the phone line audio on the other channel. A second output jack contains a mix of both voices. Front panel control for each output offers all the control you will need. The Inline Patch does not disrupt your Caller ID or ring signals.

For telecom demo or teleconference presentations, you can use a cordless telephone. Walk around the room and talk over the phone while everyone listens in. Let the audience try your IVR application. The **<Off Hook/Normal>** switch lets you seize a phone line without using a telephone. This switch can be remote-controlled with a simple contact closure.

The Inline Patch is also perfect for television or cable talk show use, when you may need access to audio from a working telephone on camera.

### Ready to go?

The Inline Patch controls and connectors are clearly marked and ready for operation. The Features diagrams and Operation sections on the following pages will help you pinpoint any minor questions that you may have. If this is your first exposure to a hybrid, we suggest that you read the entire manual to allow you to take advantage of all these features.

### Any Questions?

Before you pick up the phone... Please thumb through the rest of this manual. You might find those deep technical questions are covered on later pages.

# Getting to Know Your Inline Patch

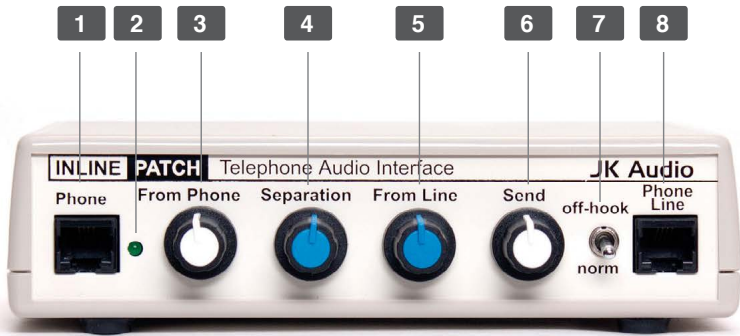

## Controls & Indicators

- 1.** Phone Jack  
Connect a single line analog telephone.
- 2.** LED  
Lit when unit is plugged in and receiving power.
- 3.** From Phone Control  
Adjusts the level of your voice on both output mini jacks.
- 4.** Separation Control  
Fine tunes voice separation. (See page 6 for tuning.)
- 5.** From Line Control  
Adjusts the level of the audio coming from the phone line on all three output jacks.
- 6.** Send Level  
Adjusts the signal level that you are sending down the telephone line.
- 7.** Off-Hook / Norm Switch  
This switch allows you to seize the phone line without using a telephone. (See page 6 for operation.)
- 8.** Line Jack  
Connect to a standard, single line, analog telephone line.

# Getting to Know Your Inline Patch

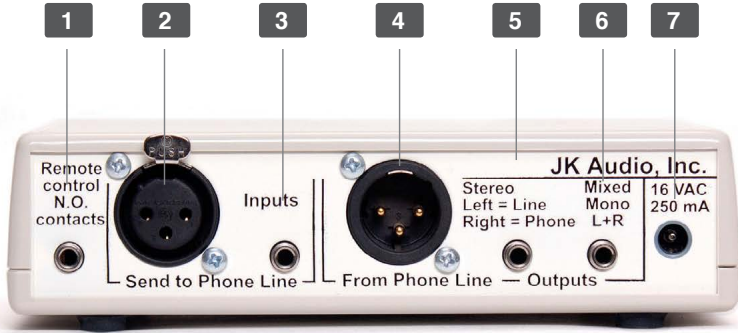

## Inputs & Outputs

- 1. Remote Control Jack**  
Connect tip to ring to go off-hook
- 2. Send Input (XLR)**  
Balanced Female XLR line input for signals going into the phone line.
- 3. Send Input (3.5mm)**  
3.5mm mono line level input for signals going into the phone line.
- 4. Phone Line Output (XLR)**  
Balanced Male XLR line output which contains only the audio coming from the phone line with a nominal 20 dB of trans-hybrid loss (your voice will be mixed with the caller's audio, but about 20 dB lower than your send level).
- 5. Stereo Output (3.5mm)**  
Phone line audio on the left channel and your voice on the right channel.
- 6. Mixed Mono Output (3.5mm)**  
Has both sides of the call combined on both left and right channels. You may use either a mono or stereo plug in this jack
- 7. Power Jack**  
For connection only to the supplied power supply.

# Getting Connected

## Setting Up for Analog Telephones

1. Unplug the telephone cord from the base of your telephone and plug it into the jack on the Inline Patch marked **<Phone Line>**.
2. Using the telephone cable we have provided, plug one end into your Inline Patch marked **<Phone>** and the other end of the cable into your telephone.



3. Connect your audio equipment to the 3.5mm and / or XLR line input and output jacks on the Inline Patch.
4. Connect the power supply to the back of the Inline Patch.

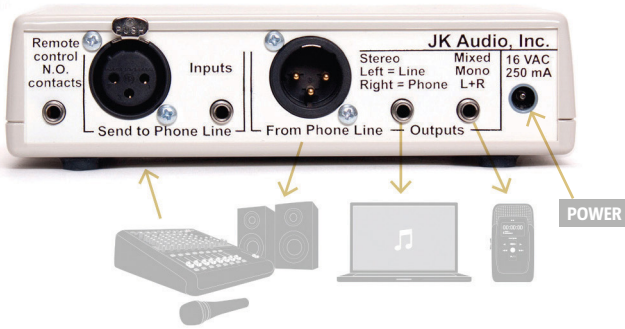

**▲ Note:** If you want to use a microphone to add extra audio to the call, you will first need to add an amplifier to your microphone so that the signal is boosted to line level. You can use both the XLR and the mini jack input at the same time, and add it to the audio coming from the handset microphone. The level of the audio you send through the input jacks into the phone line can be adjusted with the Send control. Note that this audio will come back mixed with the caller audio, so be sure not to overpower the caller's voice with your own audio.



## Setting Up for PBX Phone Systems

Setup for use with PBX phone systems is the same as for analog telephones with one exception. Some PBX telephones have a simulated analog line extension jack called a data / modem port. Instead of connecting the **<Phone Line>** jack of the Inline Patch to a wall jack, you will connect to the data / modem jack on your PBX phone. You will still need a regular analog telephone connected to the **<Phone>** jack of the Inline Patch. When dialing out you will need to take the necessary steps to get a direct connection to the main analog phone line (example: dialing 9 + 1 + phone number). You will not physically use your PBX phone while operating the Inline Patch. It simply acts as your connection to the telephone line. Dialing, speaking, etc. will be done through the separate analog telephone.



- ⚠ **Note:** Connecting the Inline Patch directly to a multi-line, PBX or ISDN phone system wall jack could irreversibly damage the unit.

# Operation

## Off-Hook/Norm switch

Set the **<Off-Hook/Norm>** switch to **<Norm>** to dial out using a telephone. Set the switch to **<Off-Hook>** to seize the line and answer an incoming call without using a telephone.

The **<Off-Hook/Norm>** switch can be remotely operated using your own switch contacts connected to the **<N.O. Contacts>** jack on the back of the unit. Simply wire a 3.5 mm plug to a normally open switch. A short across tip and ring on a stereo or mono plug will take the phone line off-hook.

## Fine Tuning the Separation

1. First connect your audio equipment (powered speakers, mixer with a VU meter, etc.) to the **<Mixed Mono>** output jack on the back of the Inline Patch.
2. Next turn the **<From Phone>** control all the way down and the **<From Line>** control all the way up.
3. Now place a phone call. Without any audio coming from the other end of the call, hold down a touch tone on your telephone while adjusting the **<Separation>** control to find the most quiet position.
4. Now turn the **<From Line>** control to about 12:00 and use the **<From Phone>** control to bring your voice up to a suitable level.

The hybrid circuitry in the Inline Patch can provide a nominal 20 dB of transmit / receive isolation. When using the stereo jack with stereo speakers, the 20 dB isolation will give you substantial left / right separation. The separation on FM stereo is typically around 20 dB.

1. I don't seem to be getting as much volume out of the XLR output as I should be. What's wrong?

Check your XLR Cable. Some Sound Engineers are in the habit of connecting the "ground wire" (pin 1) and the "negative wire" together. This is sometimes done to convert transformer output signals into a single ended output. Inline Patch uses an active differential output so grounding one of the hot pins will drop the output in half. Separate these two wires and you should hear a difference.

2. We purchased an Inline Patch to take callers on our radio show, but we've found that 20 dB of separation really isn't enough for us. What can we do?

The Inline Patch was designed primarily for interview recording and telecom demos. If you're looking for something to put callers on the air for a radio show you should purchase a digital hybrid instead. Our Broadcast Host and innkeeper 1x Digital Hybrids typically provide greater than 50 dB separation between send and receive and have great sound quality.

3. There is a hum on the output of my Inline Patch, even when nothing else is connected. What else could it be?

Make certain you are using the power supply that was shipped with the unit. Power supplies are not all the same.

4. I'm using a MP3 player with an Inline Patch to send audio down the phone line and then recording that audio with the caller's comments. The MP3 audio is overpowering the caller audio even when I turn the **From Phone** control all the way down. How should I set this up?

The **<From Phone>** control only adjusts the output of your voice that is sent through your telephone. The audio you are feeding into the inputs on the back of the Inline Patch comes back mixed with the caller's voice. The Inline Patch does not attempt to separate audio sent into the inputs, only your voice sent through your telephone. You'll have to lower the "Send" level on the Inline Patch to correct this problem.

5. There is a small amount of hum in the background of my recordings made from the Inline Patch. What's wrong?

Try turning up the **<From Line>** volume control. This will decrease line resistance and help eliminate the hum.

6. Can I connect the Inline Patch directly to my multi-line, PBX or ISDN phone system wall jack?

**NO!** Connecting the Inline Patch to any wall jack other than a single line POTS (analog) phone line or emulated analog phone line could irreversibly damage the unit. If you do not know what type of phone line you have, it is best to err on the side of caution and not connect it. Page 5 of this user guide illustrates how you may use the Inline Patch if you do not have an analog line.

# Technical Information

## Specifications

<b>Input</b>	<b>Impedence / Level</b>
Female XLR	1k ohms / 250 mV RMS; -10 dBu nom.;
1/8" (3.5mm) Mono Line	20k ohms / 250 mV RMS; -10 dBu nom.
<b>Output</b>	
Balanced Male XLR	100 ohms / 500 mV RMS; -4 dBu nom.; +14 dBu max
1/8" (3.5mm) Stereo	50 ohms / 250 mV RMS; 10 dBu nom.; +12 dBu max Left = Send; Right = Caller
1/8" (3.5mm) Mono	50 ohms / 250 mV RMS; 10 dBu nom.; +12 dBu max Mixed Send and Caller
Phone Line	RJ11C
Isolation	1500 VAC
Phone	RJ11C; Voltage 32 VDC
Remote	1/8" (3.5mm) TRS Stereo Jack. Connect tip to ring to go off hook
Power	16 VAC, 160 mA (120 VAC, UL approved, transformer supplied)
Size	6" x 4.75" x 1.65" (15.3 x 12.1 x 4.2 cm)
Weight	1.6 lbs (725 grams)

Inline Patch Block Diagram

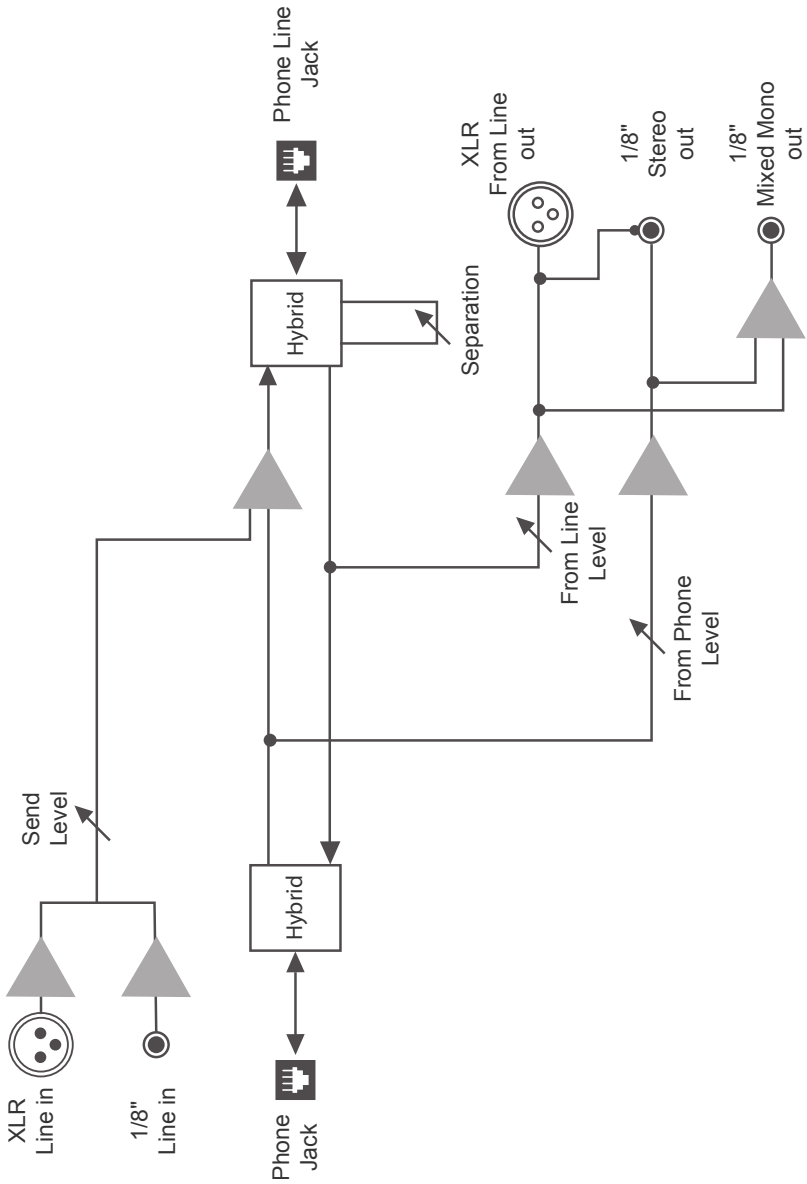

# FCC Registration

## FCC Registration

Your new JK Audio product has been registered with the Federal Communications Commission (FCC). This product complies with the standards in Part 68 of the FCC rules.

### 1. Connection and use with the nationwide telephone network

The FCC requires that you connect this telephone equipment to the national telephone network through a USOC RJ-11C modular telephone jack. This equipment may not be used with Party Line Service or Coin Telephone Lines. This equipment is hearing aid compatible.

### 2. Information for the telephone company

Upon request from your local telephone company, you are required to provide the following information:

- A. The “line” to which you will connect the telephone equipment (that is, your telephone number), and
- B. The telephone equipment’s FCC registration number. This can be found on the bottom of your telephone equipment, and,
- C. The ringer equivalence number (REN) for this equipment. The REN is used to determine the quantity of devices which will be connected to the telephone line. Excessive RENs on the telephone line may result in the devices not ringing in response to an incoming call. In most, but not all areas, the sum of the RENs should not exceed 5.0. To be certain of the number of devices that may be connected to the line, as determined by the total RENs, contact the local telephone company.

### 3. Repair Instructions

If it is determined that your telephone equipment is malfunctioning, the FCC requires that it not be used and that it be unplugged from the modular outlet until the problem has been corrected. Repairs to this telephone equipment can only be made by the manufacturer or its authorized agents or by others who may be authorized by the FCC. For repair procedures, follow the instructions outlined under the warranty section of the manual.

### 4. Rights of the telephone company

If telephone equipment is causing harm to the network, the telephone company may temporarily discontinue your telephone service. If possible, they’ll notify you before they interrupt service. If advanced notice isn’t practical, you’ll be notified as soon as possible. You’ll be given the opportunity to correct the problem, and you’ll be informed of your right to file a complaint with the FCC. Your telephone company may make changes in its facilities, equipment, operations or procedures that could affect the proper functioning of your JK Audio product. If such changes are planned, you’ll be notified by your telephone company.

### FCC Part 15 Subpart A Compliance

This equipment has been tested and found to comply with the limits for a Class A digital device, pursuant to Part 15 of the FCC Rules. These limits are designed to provide reasonable protection against harmful interference when the equipment is operated in a commercial environment. This equipment generates, uses, and can radiate radio frequency energy and, if not installed and used in accordance with the instruction manual, may cause harmful interference to radio communications. Operation of this equipment in a residential area is likely to cause harmful interference in which case the user will be required to correct the interference at his/her own expense.

Changes or modifications not expressly approved by JK Audio can void the user's authority to operate the equipment.

**Inline Patch™**

TELEPHONE AUDIO INTERFACE



**User Guide Version 1/27/14**

JK Audio, Inc.  
1311 E 6th St.  
Sandwich, IL 60548  
United States  
Telephone: 815.786.2929  
Toll Free: 1.800.jkaudio  
Fax: 815.786.8502  
[www.jkaudio.com](http://www.jkaudio.com)

© 2014 JK Audio, Inc. All rights reserved.

**JK Audio**