



# **Daptor Two™**

## Wireless Phone Audio Interface

User Guide

**JK Audio**

## Welcome

### Thank You

Thank you for purchasing the JK Audio Daptor Two. Please read this guide for instructions on setting up and using your new product.

### Getting Assistance

If you have any questions:

Call us at:

**815-786-2929**

Email us at:

**[support@jkaudio.com](mailto:support@jkaudio.com)**

Or, check out our FAQ section for answers to common questions.

### Limited Warranty

Daptor Two is covered by a 1 year warranty to be free from defective workmanship and materials. To obtain service, contact JK Audio by phone or email for return authorization.

Once authorized, you will carefully pack and ship the faulty product and all accessories to us. You will pay for shipping to us and we will pay for return back to you.

This warranty does not cover damages due to accident, weather, fire, flood, earthquake, misuse, unauthorized repairs or modifications, or damages occurred in shipping, only defective workmanship or materials.

**There are no expressed or implied warranties which extend beyond the warranty here made.**

## Contents

Overview	1
Setup	2
Compatibility	4
FAQs	5
Technical Information	6

## Features



1	Balanced XLR Line Output	4	1/4" Mono Line Input
2	Balanced XLR Line Input	5	1/4" Mono Line Output
3	4-conductor 3.5 mm Headset Interface		

## In the Box

1/4" TRS to 3.5mm TRRS cable (CN113)

### Introducing Daptor Two

Simply plug Daptor Two into the headset jack of any wireless phone or notebook computer that accepts a third party headset or earpiece. Send and receive voice band or HD Voice quality audio during regular calls, or full bandwidth audio using third party codec applications.

Daptor Two will provide the highest quality connection possible between your audio equipment and cellular telephone. However, due to the unpredictable nature of wireless telephone service we cannot guarantee excellent audio quality every time Daptor Two is used. Audio quality is still mostly dependent upon the connection provided by your wireless telephone service. As a general rule,

the better the cell phone signal, the better your audio quality will be.

You should also keep in mind that most wireless telephones have their own level controls. The first step in setting levels should be adjusting your phone volume control to obtain a clear, healthy signal. You may then adjust the gain on your other audio equipment to fine tune the levels.

# Setup



Optional: You may use the XLR jacks on top of Daptor Two or the TRS jacks on the bottom.

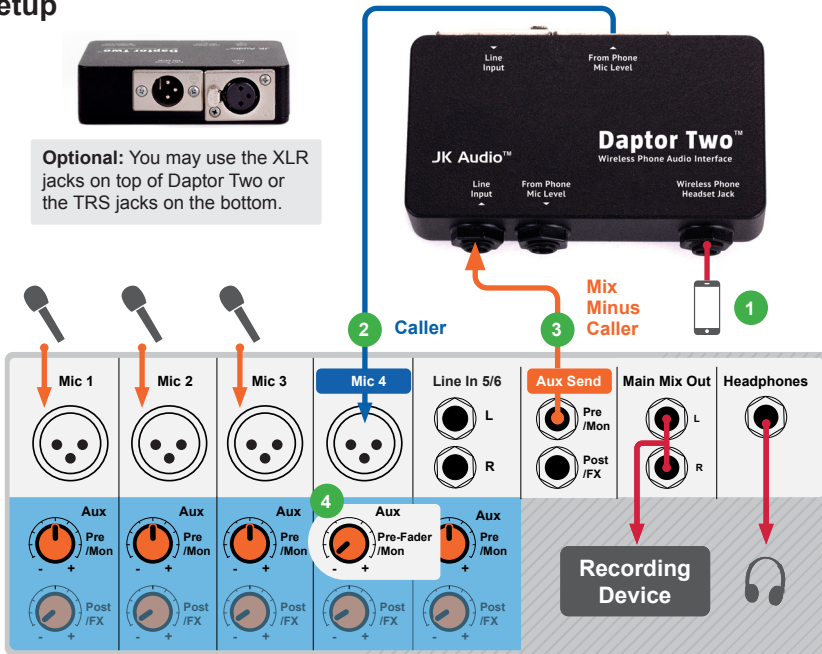

1. Connect the included CN113 cell phone interface cable between the **<Wireless Phone Headset Jack>** of Daptor Two and the 3.5 mm TRRS headset jack of your wireless phone or notebook computer.

**Note:** Wireless phones generate substantial radio frequency (RF) noise during a call which can leak into your audio cables and equipment. If you notice a problem with RF noise, be sure to keep your wireless phone one to two feet from your mixer and other audio equipment. It is also important to keep the wireless adapter cord away from any other audio cords.

2. Connect either **<From Phone>** output to any **Mic Level** input on your mixer or other audio equipment. You may use either the XLR output or 1/4" output, not both.
3. Connect the mixer's Mix-Minus bus or **Aux Send** output (this may be labeled **FX** or **Mon** but any Aux bus

will work) to either **<Line Input>** on Daptor Two. You may use either the XLR input or 1/4" input, not both.

4. Whichever input channel that Daptor Two's **<From Phone>** output is connected to, turn the corresponding **Aux** control to minimum. All **Aux** controls for other channels should be set for audio sent to the phone line. Each **Aux Send** bus is completely separate from all other outputs, so these Aux controls will not affect what is heard on the Main outputs or on any other Aux buses.

**Tip:** Using an Aux Send bus that is **Pre-Fader** allows you to control the levels of each channel to the main output without affecting what is sent to the phone line.

## Setup

If your mixer does not have an **<Aux Send>** bus, you can use **<Pan>** controls with the Left and Right outputs. Pan all the microphones, etc. to the Left output and pan the Caller to the Right output. Then connect only the **<Left>** output to the innkeeper PBX **<Send 1>**. Or, you may use an external Mix-Minus box that will create this signal for you.

5. Your device will recognize Daptor Two as a headset which will disable the internal mic and speaker. Connect a microphone and headphones to your mixer or other audio equipment. You are now able to place or receive a call.

## Wireless Phone Compatibility

Daptor Two emulates the electrical characteristics of cell phone headsets and should work with any wireless phone that accepts generic third party headsets. However, we cannot guarantee that Daptor Two will work with every wireless phone available.

With the increasing number of wireless phones that now use non-standard headset jacks, you may need to separately purchase an adapter to connect to our CN113 3.5mm TRRS cable. These adapters are sometimes provided with phones that do not use standard headset jacks. If in doubt, check with your phone manufacturer for details about compatibility with generic TRRS headset connections.



### **Will Daptor Two work with my model \_\_\_\_ cell phone?**

Yes, as long as your wireless phone has a 3.5 mm earpiece jack and accepts a generic 3rd party earpiece or headset.

### **What if my phone does not have a 3.5 mm headset jack?**

Many phone manufacturers provide adapters that allow connection of a 3.5 mm plug. You can often find these adapters where you purchased your phone or in electronics stores.

### **Can I send and receive audio at the same time?**

Yes. Daptor Two is capable of sending and receiving audio at the same time.

### **Can I talk on my handheld phone and record the conversation using a Daptor Two?**

No, most phones detect the presence of anything plugged into the headset jack and immediately disable the phones microphone and speaker.

### **Why is the audio so loud/quiet?**

The first step in setting levels should be adjusting your phone volume control to obtain a clear, healthy signal.

You may then adjust the gain on your other audio equipment to fine tune the levels.

# Block Diagram

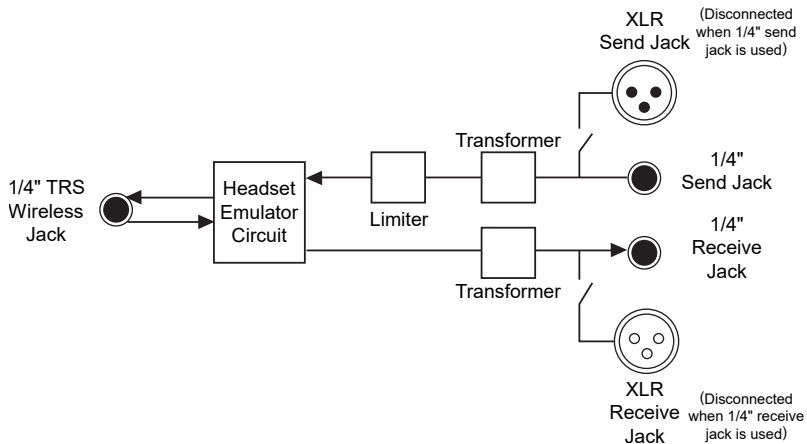

## Specifications

### Input

---

Balanced Female XLR / Unbalanced 1/4" Mono	600 ohms, 250 mV RMS (-10 dBu nom, 0 dBu max)
---	---

---

### Output

---

Balanced Male XLR / Unbalanced 1/4" Mono	600 ohms, 45 mV RMS (-25 dBu nom)
---	-----------------------------------

---

### Dimensions

---

Size:	4.4" x 2.7" x 1.2" (11.2 x 6.9 x 3.5 cm)
-------	--

---

Weight:	9 oz. (250 g)
---------	---------------

---

## **Daptor Two™**

Wireless Phone Audio Interface



**User Guide Version 7/17/23**

JK Audio, Inc.  
220 Great Circle Road, Suite 114  
Nashville, TN 37228  
United States  
815.786.2929  
[www.jkaudio.com](http://www.jkaudio.com)

© 2023 JK Audio, Inc. All rights reserved.

# **JK Audio**