



ComPack™
Universal
Telephone Audio
Interface

User Guide

Welcome

Thank You

Thank you for purchasing a JK Audio ComPack Universal Telephone Audio Interface. Please read this guide for instructions on setting up and using your new product.

Getting Assistance

If you have technical or application questions:

Call us at:

815-786-2929

Email us at:

support@jkaudio.com

Or check out our **FAQ** section for answers to common questions.

Warnings & Safety Precautions

- Read and keep these instructions.
- Follow all instructions.
- Clean only with a soft dry cloth.
- Refer all servicing to qualified service personnel.
- Heed all warnings



Caution: To prevent possible hearing damage, avoid listening at high volume levels for long periods.

ComPack contains a headphone amplifier that is more powerful than the typical consumer product.

JK Audio products are designed for the broadcast industry. The broadcast professional must be able to hear headphone signals over the ambient noise level. From the cheering crowd at a football game to trackside at a car race, the program material or cues must be heard at high volumes without distortion.



Road Safety

Never use headphones while driving or cycling, etc. It can be dangerous to turn up the volume even while walking. Doing so may hinder your hearing and can be hazardous on the roadways or at pedestrian crossings.



Handle with Care

While Compack was designed to be very rugged and durable, it is not waterproof and care should be taken to keep the unit dry.

Contents

Overview	1
Getting to know your ComPack	2
2 Front, Top, Bottom	
3 Left, Right	
Getting Connected	6
Operation	6
Telecom / Intercom Link	7
FAQs	8
Technical Information	10

Limited Warranty

The ComPack is covered by a 1 year warranty to be free from defective workmanship and materials. To obtain service, contact JK Audio by phone or email for return authorization. Once authorized, you will carefully pack and ship the faulty product and all accessories to us. You will pay for shipping to us and we will pay for return back to you.

This warranty does not cover damages due to accident, weather, fire, flood, earthquake, misuse, unauthorized repairs or modifications, or damages occurred in shipping, only defective workmanship or materials.

There are no expressed or implied warranties which extend beyond the warranty here made.

Features

Features

HD Voice Compatible (7 kHz Wide-Band Speech)

Works with Analog and Digital PBX or VoIP Phones

4-conductor 3.5mm Headset Interface

Connects to Wireless Phones & Notebooks

Headphone, Mic, and Line Input Level Controls

XLR Mic Input (Mic/Line Switch)

XLR Line Output / Com Link

3.5mm Stereo Line Input

¼" Stereo Headphone Jack

Transmit Clip LED

Battery Test LED

DTMF Keypad and Lockout Switch

Handset Selector Switch
(Electret, Carbon, Dynamic)

>20 Hours on one 9V Alkaline Battery

What's in the Box?

Detachable North American Power Cord

RJ11 Phone Cord

Wireless Phone Interface Cable

Remotely Anywhere.

Pick up this new handheld road tool to get audio in and out of analog phone lines, PBX systems, even cell phones. Perfect for Remote Broadcasts, IFB feeds, or interviews over any phone connection.

Wireless Phones and Notebooks.

Simply plug ComPack into the 3.5mm headset jack of your wireless phone or notebook computer using the 1/4" TRS to 3.5mm TRRS interface cable. Your cell phone will recognize ComPack as a headset which will disable the internal mic and speaker.

ISDN, PBX, and VoIP Systems

Unplug the handset from any phone and plug the coily cord into ComPack. You can now send and receive audio through the ISDN, PBX, or VoIP telephone set.

Analog Phones.

Plug ComPack into an RJ-11 jack, go off-hook and dial, or answer an incoming call.

Add a Phone Line to the Party Line.

ComPack also functions as a simple telecom interface for your beltpack intercom system. This no-frills feature allows you to connect the 3 pin male XLR to your wet party line. This provides a full duplex, always-on connection to any telephone network.

Ready to go?

The ComPack controls and connectors are clearly marked and ready for operation. If this is your first exposure to a hybrid, we suggest that you read the entire manual to allow you to take advantage of all these features.

Any Questions?

Before you pick up the phone... Please thumb through the rest of this manual. You might find those deep technical questions are covered on later pages.

Getting to Know Your ComPack



Controls & Indicators

- 1. Mic Input Level**

Adjusts the signal level that you are sending down the telephone line, through the female XLR input. The **<Clip>** LED indicates clipping on the input channel if the level is set too high. If you see this red LED flashing, you should decrease the **<Mic Input>**.
- 2. Line Input Level**

Adjusts the signal level that you are sending down the telephone line, through the 3.5mm mini jack input.
- 3. Headphone Level**

Adjusts the signal level coming from the 1/4" headphone jack.

Controls & Indicators

4. Power Switch

The power switch should be left in the **<Off>** position any time the unit is not being used or battery drain will occur. The unit will retain a phone line connection if the power switch is turned off during a call.

5. Phone Line Switch

When using the analog <Phone Line> jack, this switch acts as the switchhook for the telephone line.

When you want to place or answer a call, switch to the **<Dial/Talk>** position. The **<On Hook>** position is when you are not using the line or you are waiting for a call.

When using the Universal PBX Handset or Wireless Phone Headset Interface, the switch should remain in the <On Hook> position at all times.

6. Keypad Switch

This switch disables the DTMF keypad to prevent tones from being blasted down the phone line during a broadcast. You should leave this switch in the **<Off>** position when using the **Wireless Phone Headset** or **Universal PBX Handset Interface**.

7. DTMF Keypad

Dial a number when connected to an analog telephone line. The transmit audio is muted during a keypress.

Inputs & Outputs

8. Mic In

The female XLR input can be used for either the connection of a dynamic microphone or a line level audio signal such as from an audio mixer. This input can be used at the same time as the 3.5mm line input.

9. Mix Out / Com Link

The Male XLR output can be used in two ways: as a balanced, fixed level mixed mono output or as a bi-directional telecom link for your beltpack intercom system.

10. Headphones

The headphone output is a 1/4" 3-conductor jack. Both the tip and ring of this jack contain the same audio signal. Either mono or stereo headphones may be used.

Getting to Know Your ComPack

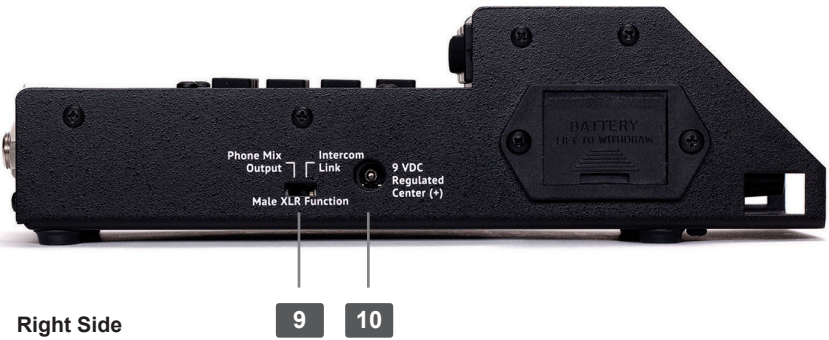
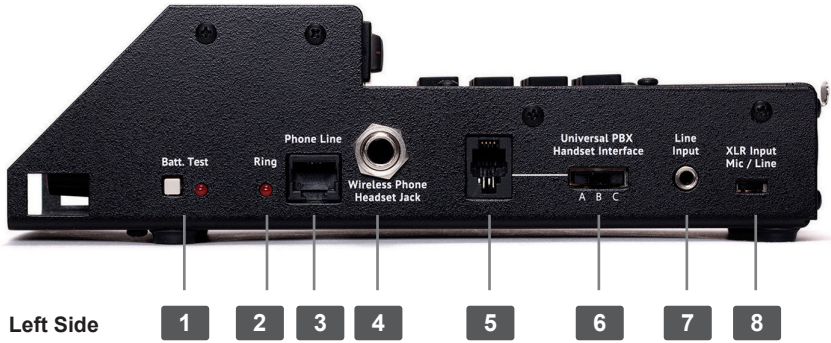

Controls, Indicators & I/O

1. Battery Test

Press this button to test the battery, the LED indicates if it has a charge. The unit may still function if the LED does not light, but there may be significant audio distortion and a loss of level as the battery continues to discharge. Under normal use you should get at least 20 hours of continuous use from one 9 volt alkaline battery.

2. Visual Ring Indicator

The Ring LED will flash when there is an incoming call from the phone line. This feature is disabled when ComPack is being used with the handset interface or the wireless phone interface.

3. Phone Line

Use this jack to connect to standard analog telephone lines. This jack should not be connected directly to digital PBX or ISDN phone systems.

4. **Wireless Phone Headset Interface**

This interface works with any wireless phone or notebook that accepts standard third party headsets and earpieces. Your product has been supplied with a 1/4" TRS to 3.5mm TRRS interface cable. While the majority of current wireless phones use a 4-conductor, 3.5mm TRRS headset jack, some older phones use a 2.5mm TRS headset jack. If your phone uses this smaller 2.5mm headset jack, you may contact our support department to request a compatible interface cable.

When using the wireless interface, it is important to keep your wireless telephone 12" - 24" away from the ComPack and any microphone or headphone cables. This will help prevent unwanted RF noise from entering the unit.

5. **Universal PBX Handset Interface**

If you do not have access to an analog phone line or if the phone system is a digital or analog PBX, ISDN, VOIP or a key telephone system, you can use the built-in handset interface. Disconnect the telephone handset from the coily cord and plug the cord into the ComPack **<Universal PBX Handset Interface>** jack. Dialing must be done with the existing telephone. Make sure to leave the telephone handset off hook or your call will be disconnected. Do not connect a handset to the ComPack; you must talk through your mic.

6. **Handset Type Selector Switch**

Select the best handset type. Trial and error works faster than a chart of handset types, but this basic description may help.

A=Electret, B=Carbon, C=Dynamic

7. **Line Input**

The 3.5mm input is a mono, line level input. This input can be used at the same time as the XLR input.

8. **XLR Input Mic/Line Selector**

Selects whether the female XLR is to be used as a mic level or line level input.

9. **Male XLR Function Selector**

Selects how the male XLR jack will be used.

Set to **<Phone Mix Output>** for a mix of the telephone caller and the microphone or line input from the female XLR jack.

Set to **<Intercom Link>** to provide bidirectional audio for use with your intercom belpack system.

10. **9 VDC Power Jack**

ComPack is powered by one 9V battery or the included AC adapter. The AC adapter is for powering the unit only, it does NOT charge the battery. The battery is bypassed when power is supplied by the AC adapter. The battery should be removed if it is not going to be used for extended periods of time.

Getting Connected

Setting Up

1. Connect your microphone (and/or line input) and headphones to the input and output jacks on ComPack.
2. There are 3 ways to connect the ComPack to the phone line:
 - A. **For Analog Phones:** Connect the jack marked **<Phone Line>** to any standard analog telephone line.
 - B. **If there is no access to an Analog Phone Line:** Disconnect the handset on an existing telephone and plug the coily cord from the phone into the **<Universal Handset Interface>** jack on ComPack.
 - C. **If there is no Land Line:** Connect the **<Wireless Phone Interface>** jack to the headset jack on your cellular telephone using the supplied JK Audio interface cable.
3. Connect the supplied AC power cord to the ComPack and then to an AC power outlet if an outlet is available.



This device should be connected to an adequate surge protective device at all times both for the power connector and for the telephone line to avoid damage from lightning or electrical surges.

Operation

A. For Analog Phones:

1. Flip the **Power Switch** to **<On>**
2. Flip the **Phone Line Switch** to **<Dial/Talk>**.
3. Flip the **Keypad Switch** to **<On>**.
4. Dial Your Call using the keypad on the ComPack.
5. To hang up, flip the **Phone Line Switch** to **<On Hook>**.

B. For PBX, VoIP, or ISDN phones:

1. Disconnect the telephone handset from the coily cord and plug the cord into the ComPack **<Universal PBX Handset Interface>** jack. ComPack should be plugged into the telephone base, not the wall jack.
2. The **Phone Line Switch** should be left in the **<On Hook>** position.
3. The **Keypad Switch** should be left in the **<Off>** position.
4. To place or answer a call, take the handset off hook. Dialing must be done from the telephone itself.
5. To hang up, place the handset back on hook.

C. For Wireless phones:

1. Connect the **<Wireless Phone Headset Jack>** to the 3.5mm headset jack on your wireless phone using the supplied TRRS interface cable.
2. The **Phone Line Switch** should be left in the **<On Hook>** position.
3. The **Keypad Switch** should be left in the **<Off>** position.
4. Dialing and answering of calls must be done from the telephone itself.

Telecom / Intercom Link

ComPack also functions as a simple “no-frills” telecom link for your beltpack intercom system. ComPack will provide bi-directional audio on pin 3 of the male XLR jack to any industry standard intercom beltpack system. ComPack does not provide power over this XLR jack nor does it require power from the loop.

Note: ComPack will not recognize a call signal generated by your intercom system and it will not provide one.

1. Slide the Male XLR selector switch to the **<Intercom Link>** position. This recessed switch is located near the power jack. Accessing the switch can be done using a small blade screwdriver, or other such object, inserted into the opening. The left position (towards the XLR jacks) designates Line Output. The right position (towards the volume controls) designates Com Link. The factory default position of this switch is Line Output.
2. Connect your beltpack intercom XLR cable to the ComPack **<Mix Out / Com Link>** jack. The XLR jack is wired as:
 - Pin 1:** Ground
 - Pin 2:** Open
 - Pin 3:** Two-Way Audio
3. Your intercom headset should remain plugged in to your beltpack system, not directly into ComPack.

FAQs

1. How do I select which telephone interface to use (analog phone line, PBX, or wireless)?

Actually, all three connections are live all the time. Technically, you could connect to all three at once, but since there is no way to equalize levels, this “conference call” might not be the best quality connection.

2. Will ComPack work with any cell phone?

ComPack has been tested with many popular brands and model phones that use the 3.5mm 4-conductor TRRS style headset. However, there are no industry standards, so we cannot promise compatibility with any brand or model phone.

3. Can I talk on my cell phone while I record the call?

No, most phones detect the presence of anything plugged into the headset jack and immediately disable the phone’s microphone and speaker.

4. Can I send and receive audio at the same time?

Yes, but whatever audio you send into the ComPack will come back mixed with the caller audio.

5. Will ComPack provide phantom power for my mic?

No, ComPack will not provide phantom power. If you are connecting your microphone directly to a ComPack, you should use a dynamic mic.

6. The output from my Mic is low.

Check the position of the <Mic/Line> switch on the side near the Mic jack. This input can be switched to accept a line level signal from a mixer or other equipment.

7. How can I record my conversation?

Slide the Male XLR function switch to <Phone Mix Output> and you can connect the ComPack Male XLR to your mixer or recording device for a nice mix of both sides of the conversation.

8. Can I connect ComPack to a powered beltback line?

Yes, the ComPack has a DC blocking cap so it will not be damaged if connected to a powered line, although DC power is not necessary for operation. You must switch the Male XLR Function switch to <Com Link> for proper operation.

9. I've lost the power supply for my ComPack. I have another power supply that fits from a different product. Can I use this instead?

No! Never use a power supply other than the one that was supplied by your manufacturer. Power supplies are available in either AC or DC output with many combinations of voltage and available current. Most consumer power supplies are not regulated. This could invariably damage your equipment, and also create a great deal of noise. Our products are designed for and tested with their respective power supplies for optimum operation. If you have lost your power supply, please contact your JK Audio dealer or our Customer Service department and ask for a power supply for your ComPack.

Technical Information

Block Diagram

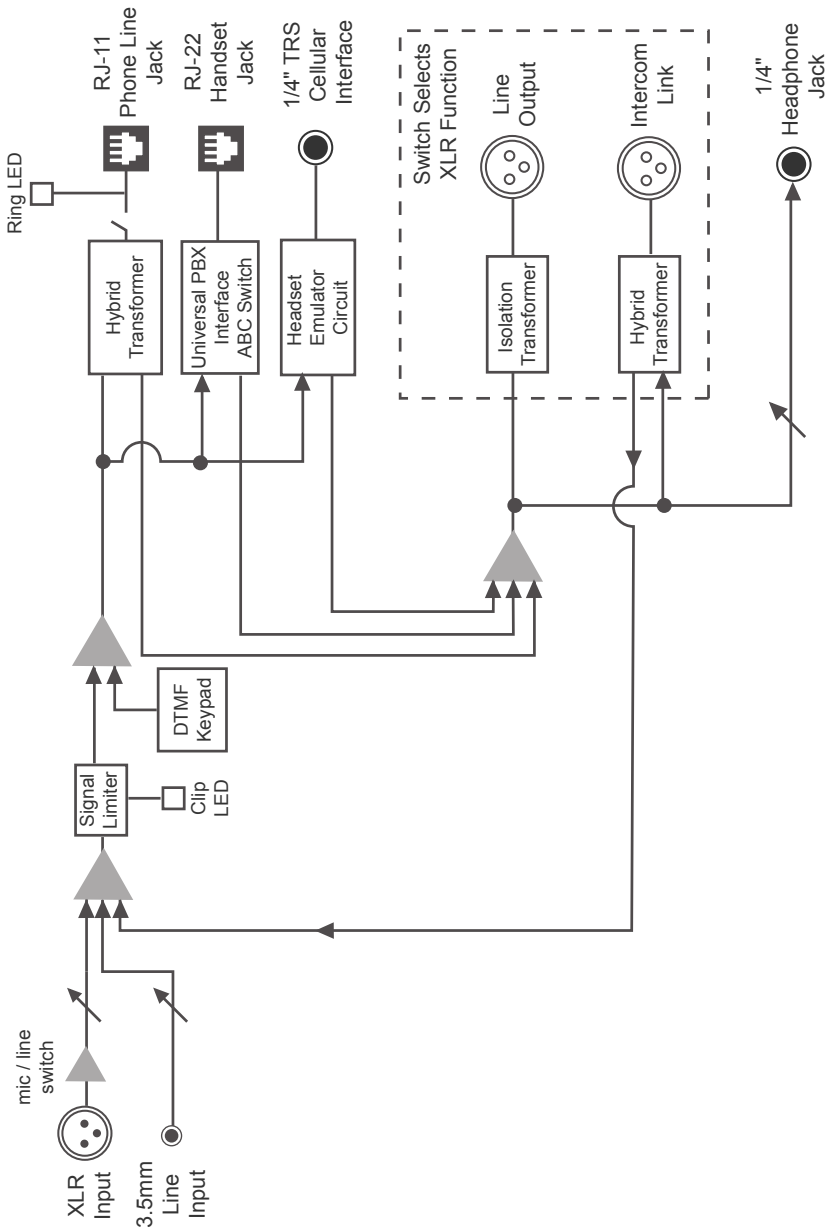

Specifications

Input	Impedance / Level
Female XLR:	1k ohms / 15 mV RMS; -34 dBu nom.; Mic/Line Pad Switch = +6 dBu max
1/8" (3.5mm) Stereo:	20 k ohms / 250 mV RMS; -10 dBu nom.

Output

Male XLR:	Phone Mix Mode: 600 ohms / 45 mV RMS; -25 dBu nom. Intercom Link Mode: Bi-Directional Unbalanced
1/4" Stereo Headphone:	8 ohms, 1/2 watt

Misc

Phone Line:	RJ11C
Ringer:	0.9B REN
Isolation:	1500 VAC
Keypad:	DTMF
Power:	One 9 volt battery or AC power supply (included)
Size:	8" x 3" x 2.2" (20.3 x 7.6 x 5.6cm)
Weight:	1.5 lbs (680 g)

Declaration of Conformity

Declaration of Conformity

Manufacturer's Name: JK Audio, Inc.
Manufacturer's Address: 1311 E 6th Street
Sandwich, Illinois 60548 USA

Declares that the product:

Product Name: ComPack Universal Telephone Audio Interface
Model Numbers: ComPack

Conforms to the following Product Specifications:

Safety: AS/NZS 60950.1:2003
CAN/CSA-C22.2 No. 60950-00 3rd edition
UL Standard 60950 3rd edition

ESD: EN 55024:1998
EN 61000-3-2
EN 61000-3-3

Emissions: EN 55022:1998
AS/NZS 3548 (1995)
FCC Part 15, Subpart B
ICES-003

Telecom: AS/ACIF S002:200
FCC CFR 47, Part 68

Declaration of Conformity

The product herewith complies with the requirements of the following Directives and carries the CE marking accordingly:

LVD 2006/95/EC (Safety)
R&TTE 1999/5/EC (Telecom)
EMC 89/336/EEC (ESD immunity)
RoHS Directive 2015/863

The Technical File containing supporting documentation is maintained at:

JK Audio, Inc (Corporate Headquarters)
Compliance Manager
1311 E 6th Street
Sandwich, Illinois 60548 USA
815-786-2929 phone
815-786-8502 fax

FCC Registration

FCC Registration

Your new JK Audio product has been registered with the Federal Communications Commission (FCC). This product complies with the standards in Part 68 of the FCC rules.

1. Connection and use with the nationwide telephone network

The FCC requires that you connect this telephone equipment to the national telephone network through a USOC RJ-11C modular telephone jack. This equipment may not be used with Party Line Service or Coin Telephone Lines. This equipment is hearing aid compatible.

2. Information for the telephone company

Upon request from your local telephone company, you are required to provide the following information:

- A. The "line" to which you will connect the telephone equipment (that is, your telephone number), and
- B. The telephone equipment's FCC registration number. This can be found on the bottom of your telephone equipment, and,
- C. The ringer equivalence number (REN) for this equipment. The REN is used to determine the quantity of devices which will be connected to the telephone line. Excessive RENs on the telephone line may result in the devices not ringing in response to an incoming call. In most, but not all areas, the sum of the RENs should not exceed 5.0. To be certain of the number of devices that may be connected to the line, as determined by the total RENs, contact the local telephone company.

3. Repair Instructions

If it is determined that your telephone equipment is malfunctioning, the FCC requires that it not be used and that it be unplugged from the modular outlet until the problem has been corrected. Repairs to this telephone equipment can only be made by the manufacturer or its authorized agents or by others who may be authorized by the FCC. For repair procedures, follow the instructions outlined under the warranty section of the manual.

4. Rights of the telephone company

If telephone equipment is causing harm to the network, the telephone company may temporarily discontinue your telephone service. If possible, they'll notify you before they interrupt service. If advanced notice isn't practical, you'll be notified as soon as possible. You'll be given the opportunity to correct the problem, and you'll be informed of your right to file a complaint with the FCC. Your telephone company may make changes in its facilities, equipment, operations or procedures that could affect the proper functioning of your JK Audio product. If such changes are planned, you'll be notified by your telephone company.

FCC Part 15 Subpart A Compliance

This equipment has been tested and found to comply with the limits for a Class A digital device, pursuant to Part 15 of the FCC Rules. These limits are designed to provide reasonable protection against harmful interference when the equipment is operated in a commercial environment. This equipment generates, uses, and can radiate radio frequency energy and, if not installed and used in accordance with the instruction manual, may cause harmful interference to radio communications. Operation of this equipment in a residential area is likely to cause harmful interference in which case the user will be required to correct the interference at his/her own expense.

Changes or modifications not expressly approved by JK Audio can void the user's authority to operate the equipment.

ComPack™

Universal Telephone Audio Interface



User Guide Version 7/17/23

JK Audio, Inc.
220 Great Circle Road, Suite 114
Nashville, TN 37228
United States
815.786.2929
www.jkaudio.com

© 2023 JK Audio, Inc. All rights reserved.

JK Audio