

BluePack

Wireless Audio Interface



User Guide

JK Audio

Description

BluePack allows live man-on-the-street interviews through a cell phone that is equipped with *Bluetooth** Wireless Technology. This sleek belt pack provides a professional look and feel to field reporters and remote talent.

BluePack pairs to your cell phone like a *Bluetooth* wireless headset. This professional microphone preamp and powerful headphone amplifier make sure the message gets through. A 3.5 mm stereo line input jack allows recordings to be mixed into the broadcast.

* The ***Bluetooth*** word mark and logos are owned by the ***Bluetooth*** SIG, Inc. and any use of such marks by JK Audio, Inc. is under license. Other trademarks and trade names are those of their respective owners.

Safety Precautions



BluePack contains a headphone amplifier that is more powerful than a consumer product. JK Audio products are designed for the broadcast industry.

The broadcast professional must be able to hear headphone signals over the ambient noise level. From the cheering crowd at a football game to track-side at a car race, the program material or cues must be heard at high volumes without distortion.

Road safety

Never use headphones while driving or cycling, etc. It can be dangerous to turn up the volume even while walking. Doing so may hinder your hearing and can be hazardous on the roadways or at pedestrian crossings.

Note: While BluePack was designed to be very rugged and durable, it is not waterproof and care should be taken to keep the unit dry.

Features

1. This thumbwheel will control the level of your microphone input.
2. The peak LED indicates clipping on the input channel if the level is set too high. The microphone and Aux Send are a combined input. If you see this red LED flashing, you should decrease the Mic and/or Aux Send input levels.
3. This control will adjust the level of audio from the 3.5 mm Aux Send input jack.



Features

4. This LED flashes red when the BluePack has a stereo listen-only audio connection to your *Bluetooth* device. If the music is paused, such as when you receive an incoming phone call or the music player is shut off, the red stereo LED will turn off until the music resumes playing.
5. This LED flashes blue when setting up or using a *Bluetooth* connection. See page 11 for timing diagrams. The LED will illuminate briefly when the unit is first powered on.
6. The Headphones control will set the level of audio sent to the headphone output jack.
7. This red LED indicates when the power is turned on.
8. Press this Power button in to activate the unit. Press again to turn the unit off.
9. The blue Multi-Function Button (MFB) is used to establish a connection with your *Bluetooth* enabled cell phone, laptop or other device.

Connection

1. Connect your headphones to this 1/4" jack. The 1 watt stereo headphone output gives you a mix of the XLR mic input, 3.5 mm Aux Send input and Bluetooth audio.
2. The unbalanced 3.5 mm stereo fixed line level output jack provides your full bandwidth microphone signal on the left channel and *Bluetooth* audio on the right channel.

Like any phone call, live interviews are limited to 3.4 kHz voice bandwidth back to the station. This stereo output jack allows you to make a full bandwidth recording using your favorite recorder for transfer back at the station or over the web.

3. Connect the output of your other audio equipment to this unbalanced stereo 3.5mm Aux Send jack. This enables you to add background music or sound clips to your Bluetooth broadcast. This audio is not present at the Stereo Output but will be sent to the Headphone jack.

Connection

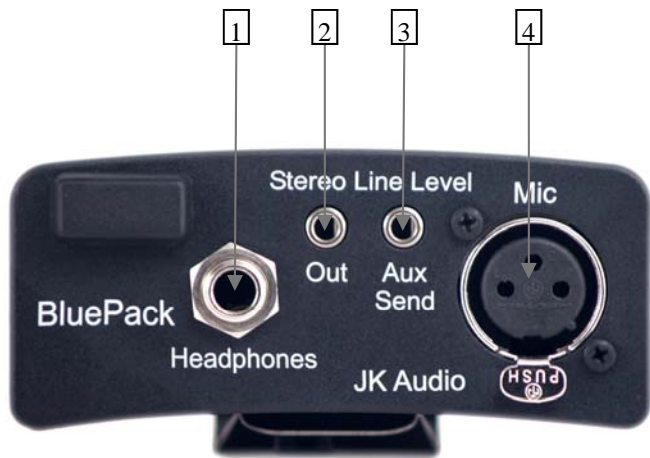

4. Connect your dynamic microphone to the XLR jack. This device will not provide phantom power for a condenser type microphone.

You can use both the balanced XLR and unbalanced 3.5 mm inputs simultaneously. The line level Aux Send input allows recordings to be mixed into the broadcast with your microphone to be sent out through your *Bluetooth* connection.

Bluetooth Wireless Technology

Establishing a *Bluetooth* connection varies with different cell phones. On your phone, find and select the option to set up a connection. Press and hold the blue button (Multi-Function Button or MFB) on BluePack for a full 5 seconds and release. The blue LED will flash rapidly, about every 100 ms, as BluePack enters Pairing Mode.

There is a difference between “Pairing Mode” and “Idle Mode”. The very first time you connect to a new device you must be in Pairing Mode. When you hold the *Bluetooth* MFB in for 2 seconds and release, the blue LED will come on steady for a moment, then it will flash at a rate of 200 ms on and 2 seconds off. This first stage is Idle Mode. Holding the MFB in for 5 seconds before release will activate pairing mode. In pairing mode the LED flashes rapidly, about every 100 ms. Once in pairing mode, any *Bluetooth* enabled device within range can pair with BluePack. After pairing is complete, the connection to that device is secure.

Now go to your *Bluetooth* device and search for *Bluetooth* connections. If this is the first time you have paired with this device, select the option to add an audio device. When the cell phone has

Bluetooth Wireless Technology

found the new device, select from the list the device ID of "JKBPxxxx" where the "xxxx" corresponds to the last 4 digits of the unit's serial number. Enter "Yes" when asked to Bond with this device. Enter the pin number as "0000". The BluePack can maintain up to 16 devices in its connection history to make reconnecting to a previously used device simpler and quicker.

When bonding is complete, the blue LED will flash at a rate of 1 sec on, 2 sec off. Once BluePack has been added to your cell phone, subsequent connections can be made more quickly from Idle Mode.

To disconnect from the *Bluetooth* device, simply press the MFB and hold for 5 seconds. Depending on the model of cell phone, if left unused in Idle Mode or if a live call is disconnected, the BluePack may automatically disconnect *Bluetooth*.

To clear the connection history and return to factory reset, hold the MFB button in for at least 20 seconds. After resetting, the BluePack will return to pairing mode.

Bluetooth Wireless Technology

The *Bluetooth* interface will first attempt to connect in Hands Free mode to a cell phone, allowing 3.4 kHz telecom bandwidth. If this is not available, it will attempt to connect in Wireless Headset mode to any product, such as a laptop computer, that allows a *Bluetooth* wireless audio connection. The Wireless Headset mode offers 20 kHz audio bandwidth.

BluePack supports A2DP (Sink), Hands Free and Headset profiles with BlueCore 5-Multimedia technology. You will be able to receive full bandwidth stereo audio from any cell phone that supports A2DP.

While all phones and portables are different, typically if you connect in cell phone Hands Free mode, you will have a mono full duplex connection. If you connect to a music player, you will be in stereo mode. Consult your cell phone or portable device for more details.

Bluetooth Wireless Technology

Bluetooth LED pattern to initiate Bonding



Hold **Bluetooth MFB** in at least 5 sec to reach Pairing Mode the first time a new device is connected, > 2 sec thereafter to easily connect from Idle Mode

Bluetooth LED pattern after Bonding

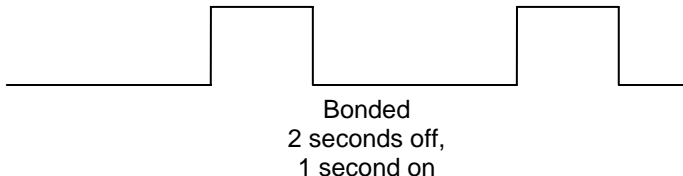

Applications

Live Man-on-the-Street Broadcasts

Cover that breaking news story, conduct live interviews from the convention floor or broadcast play-by-play action from the football field.

Connect your microphone and headphones to the BluePack as shown, then establish a *Bluetooth* connection to your wireless phone. Dial up the studio and you are ready to go. Add pre-recorded sound clips or background music to your interviews through the Aux Send input.

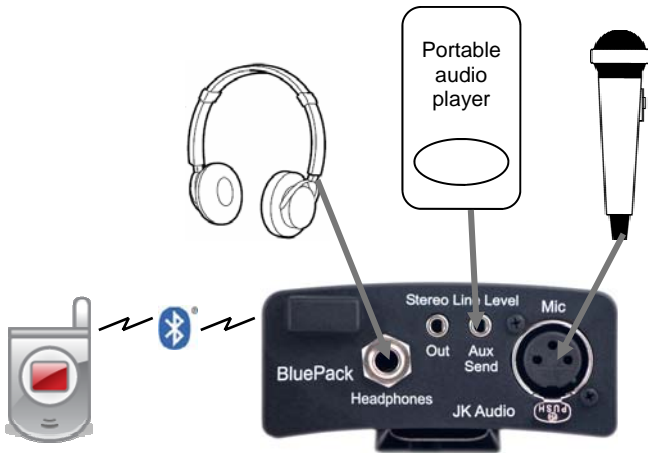

Applications

Mic Pre-amp

Connect your dynamic microphone to the XLR jack and connect the line level 3.5 mm output to your other audio equipment. Use the thumbwheel on the top of the BluePack to set the volume level for the mic input.

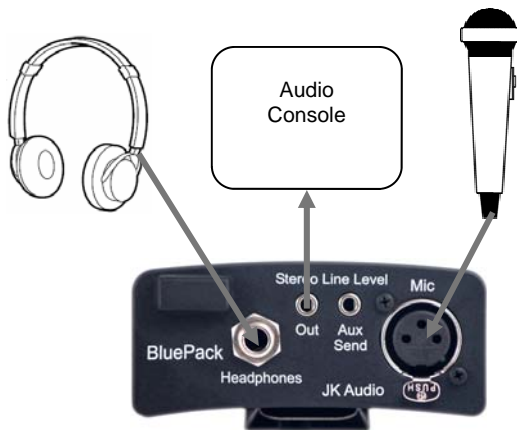

Applications

Telephone Interviews

Call out and interview other people as part of your pre-game show. Connect your mic and headphones as shown and send audio through the line output to your laptop for live streaming or to your portable recorder for later broadcast.

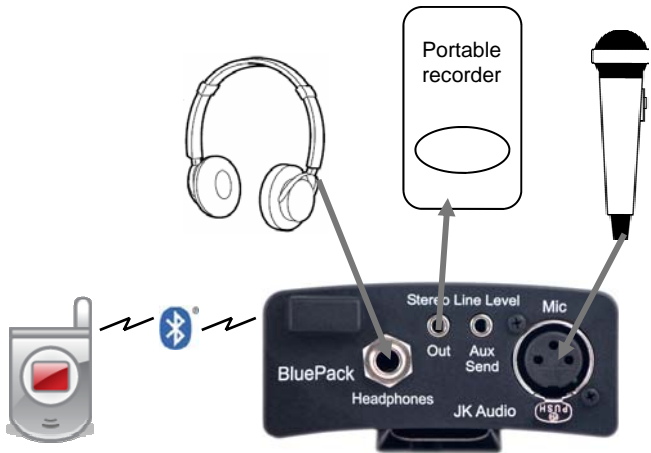

Block Diagram

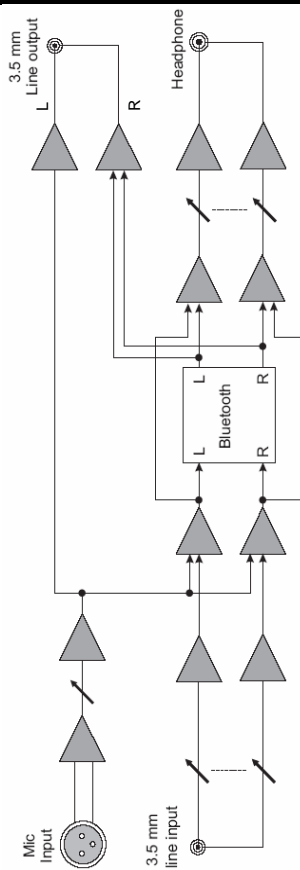

FAQs

? What is the range of the *Bluetooth* transmitter/receiver?

! BluePack will transmit and receive audio signals up to 30 feet (10 meters) from your *Bluetooth* device. Because transmitting signals over longer distances will require more power, you should keep BluePack as close as possible to your *Bluetooth* device to conserve battery power.

? Can I pair my BluePack to two cell phones and send my audio to two locations simultaneously?

! No, your BluePack can only be paired to one *Bluetooth* enabled device at a time.

? How long will the battery last?

! Based on our tests using a standard alkaline battery, with BluePack about 1 meter from a *Bluetooth* device the battery should last for about 10 hours under normal use. Lithium batteries can significantly increase the battery life, but at a higher cost. As an indicator of low battery, the red power LED will grow dim and then extinguish a short while before the battery is completely exhausted and the unit shuts down.

FAQs

? If I have an audio source connected to the Aux Send input, will that audio also be present at the Output mini jack?

! No, the stereo mini jack output only contains audio from the Mic input and the *Bluetooth* source. This input would be a good place to add background music or sound clips during a live interview that is being sent to your broadcast studio over your Bluetooth connection.

? Can I send and receive audio at the same time?

! Yes you can! You can have full duplex conversations with your microphone sent to the Left channel of the stereo line output and the *Bluetooth* audio sent to the Right channel.

? Why is the peak LED still red after I turned down the mic volume level?

! The microphone and Aux Send are a combined input. If you see this red LED flashing, you should decrease the Mic and/or Aux Send input levels until the combined input is no longer clipping.

Specifications

Inputs:

Female XLR:	Balanced, 2k ohms, -35 dBu nom.
Stereo Line In:	Unbalanced, 3.5mm, 20k ohm, -10 dBu nom.

Outputs:

Stereo Line Out:	Unbalanced, 3.5mm, 100 ohms, -10 dBu nom.
Left:	Mic at line level
Right:	<i>Bluetooth</i> return
Headphone mode:	8 ohms, 1 watt per Channel

Bluetooth

Standard:	<i>Bluetooth 2.0</i>
Distance:	30 feet (10 meters)
Frequency response	
Hands Free mode:	300 Hz - 3400 Hz
Headset mode:	TX 30 Hz - 17 kHz RX 30 Hz - 20 kHz

Power:	One 9-volt battery
Size:	4.7" x 3.75" x 1.65" (12 x 9.5 x 4.2 cm)
Weight:	10 ounces

FCC-B Part 15 Compliance

This device has been tested and found to comply with the limits for a Class B digital device, pursuant to Part 15 of the FCC rules. These limits are designed to provide reasonable protection against harmful interference when the equipment is operated in a commercial environment. This equipment generates, uses and can radiate radio frequency energy and, if not installed and used in accordance with the instruction manual, may cause harmful interference to radio communication. Operation of this equipment in a residential area is likely to cause harmful interference, in which case the user will be required to correct the interference at his/her own expense.

Changes or modifications not expressly approved by JK Audio can void the user's authority to operate the equipment.

Shielded interface cables and AC power cord, if any, must be used in order to comply with the emission limits.

The internal antennas used for this mobile transmitter must not be co-located or operated in conjunction with any other antenna or transmitter.

Warranty

The model BluePack is covered by a 2 year warranty to be free from defective workmanship and materials. In the event that the BluePack needs repair, you must call us to get an authorization, and then carefully pack and ship it to us. You will pay for shipping to us and we will pay for return back to you, UPS ground. No free repairs will be made if the defect was caused by misuse, weather conditions, or other cause, except for defective workmanship or materials.

THERE ARE NO EXPRESSED OR IMPLIED WARRANTIES WHICH EXTEND BEYOND THE WARRANTY HERE MADE.

8/08

JK Audio, Inc. 1311 E 6th Street, Sandwich, IL 60548 USA
Voice: (815) 786-2929 Toll Free: 800-JK-Audio
Fax: 815-786-8502

info@jkaudio.com www.jkaudio.com

Copyright © 2008 JK Audio, Inc. All rights reserved.