

tor Three™  
ss Audio Interface

JK Audio™

Line In Line Out

etooth®

**JK Audio**  
CELEBRATING OUR 16TH YEAR

RemoteAmp  
Blue™ JK Audio™

Line Input

st



Head Phones

Power

BluePack™ JK Audio™

Mic

peak

Aux Send

st



Head Phones

Power

RemoteMix 4™ JK Audio™

-30 -24 -18 -12 -6 0 +3

Master

Bass Boost

1  
4 GHI  
7 PQRS  
\*



I was watching the evening news as they cut to a locker room interview. A few years ago you would have seen a dozen hands holding microphones with radio and television station logos. While the TV mics are clearly visible, the radio station identity has been lost in a sea of handheld digital recorders. One might argue that the subject of the interview might even respond differently if they were speaking into a "live" mic versus a recorder.

The talent holding the microphone is what separates the amateur reporter from the veteran.

Don't get lost in a sea of recorders. Stand proud with your microphone in hand, connected to your JK Audio BluePack, sending live audio to the station while capturing the moment on your favorite (out of sight) recorder.



For our friends in the ENG truck, you've got to check out RemoteAmp Blue for those last minute, "grab the camera", no time for IFB moments. We offer a true IFB connection from your Bluetooth equipped cell phone. Go ahead, place a camera down the street using a cell phone for quick IFB.

Joe Klinger  
President  
joeklinger@jkaudio.com

**Radio**

BluePack	5
RemoteAmp Two	6
Daptor Three	7
RemoteMix 4	8-9
AutoHybrid	10
RA4	10
Inline Patch	11
Broadcast Host	12
innkeeper PBX	13
PBXport	14
RIU/IP	15
innkeeper 1x/1rx/Guest Module	16-17
innkeeper 2 and 4	18-19
ComPack	20
RemoteMix C+	21
RemoteMix 3	22
RemoteMix Sport	23
Daptor One/Daptor Two	24
CellTap/VoicePath	25
QuickTap/THAT-1	26
THAT-2	27

**AV/Telecom**

RemoteAmp Blue	4
BluePack	5
RemoteAmp Two	6
Daptor Three	7
RemoteMix 4	8-9
AutoHybrid	10
Inline Patch	11
Broadcast Host	12
innkeeper PBX	13
PBXport	14
RIU/IP	15
innkeeper 1x/1rx/Guest Module	16-17
innkeeper 2 and 4	18-19
CellTap/VoicePath	25
QuickTap/THAT-1	26
THAT-2	27
Four IFB	29
TAP-1	30

**Television & Location Sound**

RemoteAmp Blue	4
BluePack	5
RemoteAmp Two	6
Daptor Three	7
RemoteMix 4	8-9
AutoHybrid	10
Inline Patch	11
Broadcast Host	12
innkeeper PBX	13
innkeeper 1x/1rx/Guest Module	16-17
innkeeper 2 and 4	18-19
ComPack	20
RemoteMix C+	21
RemoteMix 3	22
RemoteMix Sport	23
Daptor One/Daptor Two	24
CellTap	25
THAT-2	27
QuickTap IFB/RemoteAmp	28
Four IFB	29

**Computer/Web**

BluePack	5
RemoteAmp Two	6
Daptor Three	7
RemoteMix 4	8-9
Inline Patch	11
Broadcast Host	12
innkeeper PBX	13
ComPack	20
RemoteMix C+	21
RemoteMix 3	22
RemoteMix Sport	23
Daptor Two	24
VoicePath	25
QuickTap/THAT-1	26
THAT-2	27
Pureformer/Tap-1	30

All JK Audio products are made in the USA and carry a two year warranty.

**On The Web**

Be sure to check out our web site. We keep it up to date with:



- New product information
- FAQ (Frequently Asked Questions)
- Products categorized by application
- Article reprints
- Trade show information

**Wireless Phone Compatibility...**

Many JK Audio products provide connection to wireless (cell) phones. While our interface cable plugs directly into the 2.5 mm headset/earpiece jack on many telephone models, there are some telephones that are wired to prevent operation with third party equipment. In most cases, if you can use a generic, third party headset with your cell phone, you can use your JK Audio product as well. Also, while some wireless phones have an acceptable 2.5 mm jack, others require a headset adapter to convert their proprietary connector to an acceptable 2.5 mm jack. JK Audio does not offer these adapters.

**Warranty**

JK Audio products are covered by a two year warranty to be free from defective workmanship and materials. In the event that your JK Audio product needs repair, you must call us to get an authorization, and then carefully pack and ship it to us or the nearest authorized repair center. You will pay for shipping to us and we will pay for return back to you. No free repairs will be made if the defect was caused by misuse, weather conditions, or other causes, except for defective workmanship or materials. There are no expressed or implied warranties which extend beyond the warranty here made. Prices, features, and specifications subject to change without notice.

# Bluetooth®

JK Audio is proud to offer a line of new products that utilize Bluetooth Wireless Technology. These products offer seamless integration with your Bluetooth-enabled audio devices, such as cell phones and notebook computers.

While Bluetooth has become a common term, many people think of it in terms of the lightweight headset that is used to enable hands-free communication with a cell phone. While this tiny headset has freed our hands from the phone, there are many low cost (wired or wireless) headsets that have lowered the audio quality of an already challenging cell phone connection. There may be a misconception that Bluetooth Wireless Tech-

nology is to blame for these less than intelligible conversations. We're here to tell you that this is not true. Bluetooth wireless technology is used with wireless, full bandwidth headphones without static or interruption.

Our wireless products use a rock-solid, full fidelity codec to digitize the audio stream and send it to the cell phone, where it remains a digital signal all the way through the phone network. Using your professional microphone and headphones, along with our low noise mic preamp and headphone amplifier allow a vast improvement over any cell phone or hands-free headset.



The Bluetooth word mark and logos are owned by the Bluetooth SIG, Inc. and any use of such marks by JK Audio, Inc. is under license. Other trademarks and trade names are those of their respective owners.

**NEW**

# RemoteAmp Blue



JK Audio combines Bluetooth Wireless Technology with professional audio electronics in a rugged new belt pack design.

RemoteAmp Blue offers IFB monitoring through a cell phone equipped with Bluetooth Wireless Technology, as well as wired, full bandwidth stereo listening.

Pairing with your cell phone like any Bluetooth wireless headset, RemoteAmp Blue's line input jacks and separate volume controls deliver simultaneous wired operation for complete, flexible monitoring. Its 1/2 watt, 1/4" stereo headphone jack has plenty of power to cut through any crowd noise. Simply connect an IFB earpiece to the 3.5 mm earpiece jack for mono or stereo operation.

RemoteAmp Blue also pairs to Bluetooth equipped sound cards and music players in full bandwidth stereo A2DP mode.

- Listen-only device for IFB monitoring through a Bluetooth-equipped cell phone
- Voice IFB or full-bandwidth stereo music listening
- Offers wired operation in parallel with the Bluetooth connection
- XLR line level input accepts a balanced mono signal or a party line intercom feed (listen-only)
- Connect to a ClearCom/RTS/Telex 3 pin XLR party line intercom link and monitor the feed, while also listening to the Bluetooth and 3.5 mm stereo input!

**Price: \$395.00 US**

## Simplified Block Diagram

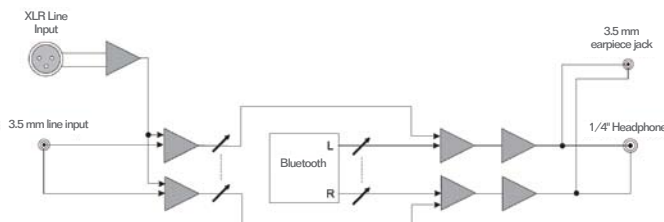

## Features

- *Bluetooth* Wireless Technology
- XLR line level input
- 3.5 mm stereo line level input
- 3.5 mm earpiece jack
- 1/4" stereo headphone jack
- >10 hours on one 9 volt battery

## Specifications

<b>Line Input:</b>	Female XLR 20 kohm (0 dBu nom)
<b>Line Input:</b>	3.5 mm Stereo 20 kohm (-10 dBu nom)
<b>Frequency Response:</b>	20 Hz – 20 kHz
<b>Earpiece Jack:</b>	3.5 mm 100 ohms Stereo, 40 mW
<b>Headphones:</b>	1/4" Stereo 8 ohms, 1/2 watt per channel

### Bluetooth:

<b>Standard:</b>	2.0
<b>Distance:</b>	25 feet (8 meters)
<b>Frequency Response:</b>	<b>Headset mode (phone):</b> 300Hz – 3400 Hz <b>Headphone mode:</b> 30Hz – 17 kHz

<b>Size:</b>	4.7" x 3.75" x 1.65" (12 x 9.5 x 4.2 cm)
<b>Weight:</b>	10 ounces (275 grams)



**NEW**

# BluePack



BluePack allows live man-on-the-street interviews through a cell phone equipped with Bluetooth Wireless Technology. This sleek belt pack provides a professional look and feel to field reporters and remote talent.

BluePack pairs to your cell phone like a Bluetooth wireless headset. Its professional microphone preamp and powerful headphone amplifier make sure the message gets through. A 3.5 mm stereo line input jack allows recordings to be mixed into the broadcast.

The 3.5 mm stereo line output jack provides your full bandwidth microphone signal on the left channel and Bluetooth audio on the right channel. Like any phone call, live interviews are limited to 3.4 kHz voice bandwidth back to the station. This stereo output jack allows you to make a full bandwidth recording using your favorite recorder for transfer back at the station or over the web.

The stereo headphone output gives you a mix of the XLR microphone input, 3.5 mm input, and Bluetooth audio. Its powerful 1/2 watt stereo headphone amplifier will cut through any crowd noise. BluePack also pairs to Bluetooth equipped sound cards and music players in full bandwidth stereo A2DP mode.

- Lets talent conduct live interviews through a Bluetooth-equipped cell phone
- Professional mic preamp and headphone amp deliver highest quality audio
- Mix the mic input (balanced XLR) and the 3.5 mm aux send for a 3.4 kHz station feed back though your phone (via Bluetooth) and/or grab a full-bandwidth mix from the stereo output to the recorder of your choice.

**Price: \$495.00 US**

## Simplified Block Diagram

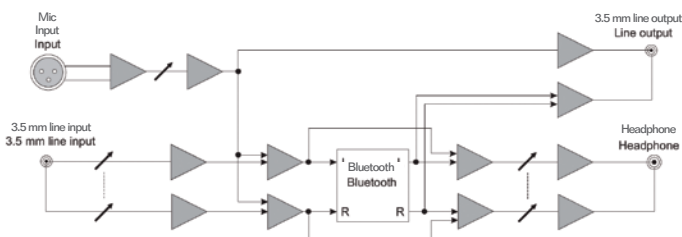

## Features

- Bluetooth Wireless Technology
- XLR mic input
- 3.5 mm stereo line input
- 3.5 mm stereo line output
- 1/4" stereo headphone jack
- >10 hours on one 9 volt alkaline battery

## Specifications

<b>Microphone:</b>	Female XLR 2k ohm (-35 dBu nom)
<b>Line Input:</b>	3.5mm stereo 20k ohms (-10 dBu nom)
<b>Line Out:</b>	3.5mm stereo 100 ohms (-10 dBu nom)
	Left = Microphone at line level
	Right = Bluetooth return
<b>Headphones:</b>	1/4" Stereo 8 ohms, 1/2 watt per channel
<b>Bluetooth:</b>	
Standard:	Bluetooth 2.0
Distance:	25 feet (8 meters)
<b>Frequency Response:</b>	Headset mode (phone): 300 Hz – 3400 Hz
	Headphone mode: 30 Hz – 17 kHz
<b>Size:</b>	4.7" x 3.75" x 1.65" (12 x 9.5 x 4.2 cm)
<b>Weight:</b>	10 ounces (275 grams)

**NEW**

# RemoteAmp Two

CE

JK Audio combines professional audio electronics in a rugged new belt pack design.

RemoteAmp Two offers two listen-only options (mono IFB or full bandwidth stereo), with separate input volume controls for easy mixing of mono and stereo sources. Its 1/2 watt, 1/4" stereo headphone jack will cut through any crowd noise. Simply connect an IFB earpiece to its 3.5 mm earpiece jack for mono or stereo operation.

**Price: \$245.00 US**

- Provides a wired, listen-only connection for mono IFB or full bandwidth stereo music listening
- Separate volume controls for XLR and 3.5 mm line inputs for simple mixing of mono and stereo sources
- XLR line level input accepts a balanced mono signal or a party line intercom feed (listen-only)
- Connect to a ClearCom/RTS/Telex 3 pin XLR party line intercom link and monitor the feed, while also listening to the 3.5 mm stereo input!

## Simplified Block Diagram

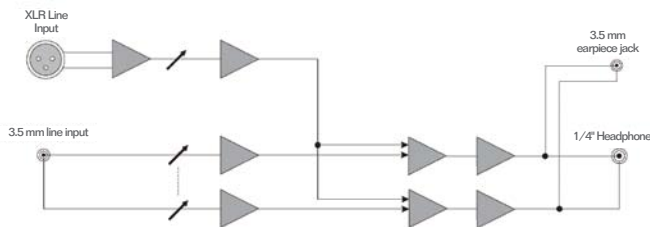

## Features

- XLR line level input
- 3.5 mm stereo line input jack
- 3.5 mm earpiece jack
- 1/4" Stereo Headphone Jack
- >20 hours on one 9 volt battery

## Specifications

Line Input:	Female XLR microphone 20 kohm (0 dBu nom)
Line Input:	3.5mm stereo 20k ohms (-10 dBu nom)
Earpiece Jack:	3.5 mm 100 ohms stereo, 40 mW
Headphones:	1/4" stereo 8 ohms, 1/2 watt per channel
Frequency Response:	20Hz – 20 kHz
Size:	4.7" x 3.75" x 1.65" (12 x 9.5 x 4.2 cm)
Weight:	10 ounces (275 grams)



**NEW**

# Daptor Three

JK Audio introduces Daptor Three, a simple, professional audio interface using Bluetooth® Wireless Technology. Like its predecessor Daptor Two, this new version allows balanced and unbalanced mono connections to your cell phone.

Daptor Three connects to your cell phone like any other Bluetooth® Wireless Technology enabled headset. Simply press and hold the recessed button on Daptor Three to initiate pairing mode. It will first attempt to connect in hands free mode to a cell phone. If this type of connection is not available, it will connect to any other product, such as a laptop, that allows a Bluetooth® wireless connection. This wireless headphone mode offers a full audio bandwidth stereo connection.

**Price: \$375.00 US**

## Specifications

**Balanced In:** Female XLR 20k ohms, -4 dBu nom  
**Stereo Line In:** 3.5mm, 20k ohms, -10 dBu nom  
**Frequency Response:** Headset (phone): 300 Hz - 3400 Hz  
 Headphone mode : 30 Hz - 17 kHz

**Balanced Out:** Male XLR 200 ohms, 0 dBu max  
**Stereo Line Out:** 3.5mm, 200 ohms, -6 dBu max  
**Frequency Response:** Headset (phone): 300 Hz - 3400 Hz  
 Headphone mode : 30 Hz - 20 kHz

**Power:** 9 VDC battery  
**Size:** 4.4" x 2.7" x 1.2" (11.2 x 6.9 x 3.5cm)  
**Weight:** 7 ounces (200 grams)





**NEW**

# RemoteMix 4

RemoteMix 4 is a four channel field mixer combined with a four channel headphone amplifier. It includes a phone line hybrid and keypad, as well as a universal PBX handset interface and a 2.5mm wireless phone interface. It can also connect to cell phones and portables using Bluetooth® Wireless Technology. All this in a tough, portable unit that's smaller than a lunch box. All-in-one is an understatement. These parts were designed to work together and save setup time in the field. No need to send an engineer with patch cables. All the pieces work together in one reliable unit.

## Radio

RemoteMix 4 was designed for sports remotes. Use it as a phone line hybrid, calling into your studio talk show hybrid. Use it as a front end mixer for your POTS, ISDN or IP codec. Use it with your laptop codec.

## TV

RemoteMix 4 gives you the ultimate phone connectivity with four IFB feeds. Imagine being able to send and receive interview audio, and pull IFB out of any business phone system, even your cell phone. More than a field mixer, this is a shoot saver.

## Great Sound

A soft limiter prevents overdriving the phone line interfaces, while the mixer XLR output is pre-limiter (full range). Bass Boost adds some low end before sending the signal down the phone line. Convenient 3.5 mm send and receive jacks for recording the show, or mixing in your MP3 player.

## Power Smart Design

Phantom power is not always needed, yet it can be a real drain on batteries. The phantom power generator only runs if any of the rear panel 48 V switches are set to "ON". Low noise, low power ICs are used throughout to preserve battery life. The low noise 100-240 VAC desktop style power supply (included) overrides the battery power only when the supply is actually providing power. If the power goes out, the batteries automatically cut in.

**Price: \$1,395.00 US**



### Features

- Separate clipping LEDs for each channel
- Headphone source selector switches, mixer out or phone mix.
- Can connect to cell phones and portables using Bluetooth® Wireless Technology.
- Master Send level control
- 7 segment LED output meter
- DTMF keypad with Redial
- Bass boost
- Four XLR mic inputs
- Mic/Line switches on channels 3 & 4
- One 3.5mm line level input
- 1/4" Line level headphone cue input
- PBX handset interface
- 2.5mm cell phone interface
- Dual 9V battery drawers
- Four 1/4" headphone output jacks with individual level controls
- 3.5mm stereo output (Mixer=L, Phone mix=R)
- Male XLR line level mixer output
- Phone line jack with hook-switch and ringer LED
- 100-240 VAC power supply included
- Switchable 48 volt phantom power on all mic inputs

### Simplified Block Diagram

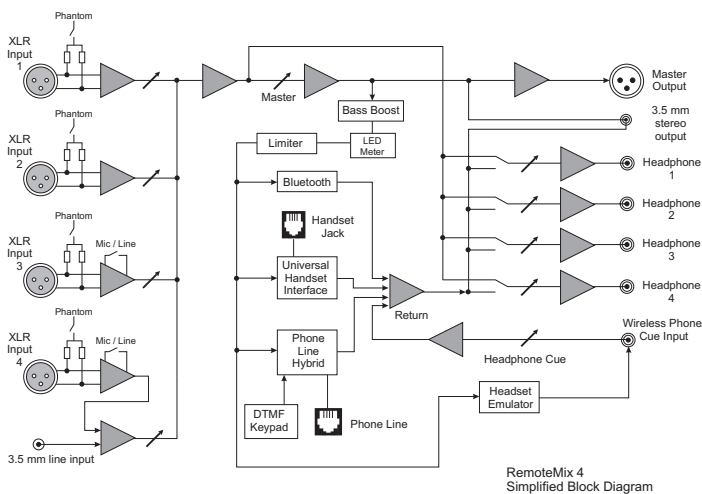

### Specifications

- Input**
- Microphones(4):** Female XLR 2k ohms (-25 dBu nom.)  
Channels 3 & 4 have Mic/Line switch  
Line = +16 dBu max, 50k ohms.
- Line Input:** 3.5 mm line input, -10 dBu nom.
- Impedance:** 20k ohms
- Headphone Cue In:** 1/4", 20k ohms, -10 dBu nom.
- Output**
- Balanced Out:** Male XLR 50 ohms, +16 dBu Max, 20 Hz – 20 kHz +/-1dB
- Stereo Line Out:** 3.5 mm, 100 ohms, -10 dBu nom.
- Headphones(4):** 1/4" Stereo 8 ohms, 1/3 watt per channel
- Phone Line Connector:** RJ11C  
Isolation 1500 VAC, Ringer 0.5B REN, Keypad DTMF
- PBX Interface:** RJ22  
PBX Handset interface simulates electret, dynamic, and carbon handset microphone types
- Wireless phone:** 36" cable provided with 2.5 mm, 3 conductor headset plug
- Size:** 9.5" x 8" x 3" (24 x 22 x 8 cm)
- Weight:** 3.8 pounds (1.7 kg)



# AutoHybrid

AutoHybrid allows simultaneous send and receive audio through analog telephone lines. This is a simple, passive, auto-answer/disconnect telephone line hybrid. Not just another half duplex auto-coupler, this is a full duplex AutoHybrid. Perfect for monitoring remote locations, IFB feeds, and many simple studio, conferencing, and PA telephone interface applications.

Yes, you can send and receive audio at the same time. The dual transformer hybrid is capable of 20 dB nominal trans-hybrid loss. In other words, your transmit signal will appear mixed with the receive signal, but at a level 20 dB lower than it was sent into the phone line.

The "Auto" feature is very simple. When the "Auto" switch is selected, AutoHybrid will answer on the first ring. The phone line will remain off-hook, or seized, until either the Drop button is depressed, or until the phone company releases the line. AutoHybrid will drop the line with either a momentary loss of line current or a polarity reversal. Keep in mind that it may

take several seconds before the phone company provides this release signal. Also keep in mind that some business PBX telephone systems do not provide this release signal.

This small desktop unit easily converts to a rack-mount unit using the optional RA4 Rack Panel. The RA4 holds four AutoHybrids in a 1U rack space.

**Price: \$175.00 US**

## Specifications

### Input

Balanced female XLR, 1k ohms, 500 mV RMS (-4dBu) nom. +6 dBu max

### Output

Balanced male XLR, 600 ohms, 200 mV RMS (-12 dBu) nom

Off-Hook LED

Auto-Answer switch

Screw terminals for:

- Off-hook control (+5 VDC momentary)
- Release control (+5 VDC momentary)
- OH LED signal (pulled to ground on OH)

Phone Line: RJ11C

Aux Phone: RJ11C

Isolation: 1500 VAC

Ringer: 0.8B REN

Frequency Response:

Telephone Side 200 Hz-3600 Hz

Size: 4" x 5" x 1.5" (10.5 x 13 x 4 cm)

Weight: 1 pound (450 grams)

## Features

- Full Duplex Hybrid
- Auto-Answer/Disconnect
- Passive design – No power required!
- XLR send jack
- XLR receive jack
- Remote control terminals
- Tough aluminum design



## Rack Mount Adapter

# RA4

The RA4 holds four AutoHybrids in a 1U rack space. That's four hybrids in a 1U space, or stack two RA4s to get 8 hybrids in a 2U rack space.... we're talking dense! What will you do with your extra rack space?

RA4 includes three removable blank covers.

Size: 19" x 1.75" (48.3 x 4.5 cm)



**Price: \$50.00 US**





# Inline Patch

This unique hybrid works with your telephone to give you more control over interview recording and playback.

The Inline Patch is a little box that connects between the base of an analog or cordless telephone and the wall jack. You can continue to talk on the phone and get access to audio on both sides of the call. The unit's two back-to-back hybrids give you complete control of audio from both sides of the call. Audio input jacks let you mix sound bytes or music into your conversation. One stereo output jack provides your voice on one channel and the caller's voice on the other channel. A second output jack contains a mix of both voices. Front-panel control for each output offers all the control you will need. The Inline Patch will not disrupt your Caller ID or ring signals.

For telecom demo or teleconference presentations, you can use a cordless telephone. Walk around the room and talk over the phone while everyone listens in. Let the audience try your IVR application.

The Off Hook/Normal switch lets you seize a phone line without using a telephone. This switch can be remote-controlled with a simple contact closure.

The Inline Patch is also perfect for television or cable talk show use, when you may need access to audio from a working telephone on camera.

**Price: \$270.00 US**

## Specifications

### Input

Balanced: Female XLR 20k ohms, 250 mV RMS (-10 dBu) nom  
 Line: 20k ohms, 1/8" (3.5 mm) mono mini jack, 250 mV RMS (-10 dBu) nom

### Output

Balanced: Male XLR 100 ohms, 500 mV RMS (-4dBu) nom. +14 dBu max  
 Stereo: 1/8" (3.5 mm) stereo mini jack 50 ohms, 250 mV RMS (-10 dBu) nom. +12 dBu max  
 Mono: 1/8" (3.5 mm) mono mini jack 50 ohms, 250 mV RMS (-10 dBu) nom. +12 dBu max  
 Remote: 1/8" (3.5 mm) TRS stereo jack Connect tip to ring to go Off-hook

Phone Line Connector: RJ11C

Isolation: 1500 volts

Phone Connector: RJ11C

Voltage: 32 VDC

Power: 16 VAC, 160 mA (120 VAC, UL approved transformer supplied)

Size: 6" x 4.75" x 1.65" (15.3 x 12.1 x 4.2 cm)

Weight: 1.6 pounds (w/power supply) (725 grams)

## Features

- Works with analog telephones or any cordless telephone
- XLR input and output jacks
- Mini stereo output jack, phone line audio on left channel, local voice on right channel
- Mini output jack, caller and local voice combined on both channels
- Mini input jack sends signal to phone line
- Mini jack for remote on-hook/off-hook
- Front panel Separation control fine-tunes voice separation
- 20 dB nominal separation of phone line transmit/receive audio

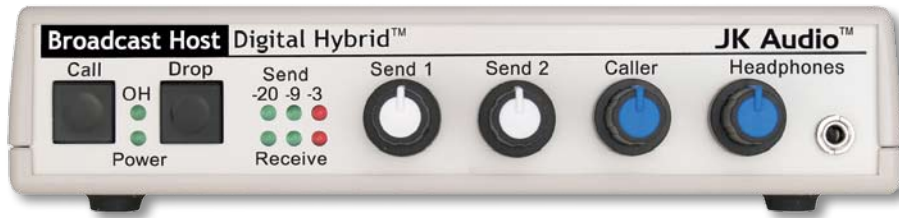

# Broadcast Host

Broadcast Host turns your desktop into a professional broadcast center. Contains everything you need to get talk show quality phone recordings into your mixer or sound card.

Connect a mic and headphones for a simple broadcast back to the station. Already at the station? Use Broadcast Host in your newsroom to record high quality interviews. Broadcast Host allows you to send mic and line level signals into the phone line while maintaining excellent separation between your voice and the caller. The stereo output jack on the back of the unit provides your voice on one channel and only the caller's voice on the other channel. The balanced XLR output jack contains only the caller's voice.

The digital hybrid connects audio signals to a standard analog telephone line without the transmit / receive crosstalk common to analog hybrids. The Digital Signal Processor (DSP) continuously monitors both the phone line and audio signals to deliver excellent separation. This proprietary, dual-convergence echo canceller algorithm can achieve excellent separation, typically exceeding 50 dB, without any setup and without sending a noise burst down the line.

Broadcast Host provides connections for a microphone, headphones, mixer, sound card, telephone and your analog telephone line. An auxiliary telephone is only required to place outgoing calls. The auxiliary telephone is disconnected when you press the "Call" button, and reconnected when you press the "Drop" button.

Broadcast Host features Auto-Answer/Auto Disconnect for use in IFB and monitoring applications. Other applications include: Podcasting/telephone interviews, talk shows, church PA interface, and conference room full duplex applications.

**Price: \$495.00 US**

## Specifications

<b>Input</b>	
Mic/Line:	Balanced Female XLR, 3.5 mm 1kohm, 20k ohms, 15 mV RMS (-34dBu) nom
Mic/Line pad switch:	Line = +6 dBu max
Line:	250 mV RMS (-10 dBu) nom
<b>Output</b>	
Balanced:	Male XLR, 200 ohms 500 mV RMS (-4dBu) nom. +14 dBu max
Unbalanced:	3.5 mm, 50 ohms, 250 mV RMS (-10dBu) nom. +6 dBu max (+4 dBv max) Left = send, Right = caller.
Headphone:	3.5 mm stereo, 8 ohms, 250 mV, mixed send and receive.
Phone Line:	RJ11C
Aux Phone:	RJ11C
Isolation:	1500 VAC
Ringer:	0.5B REN
Frequency Response:	Telephone Side 200 Hz-3600 Hz
Power:	120-240 VAC power supply (included)
Size:	7" x 6" x 1.6" (18 x 15 x 4.2 cm)
Weight:	2.2 pounds (1 kg)

## Features

- Excellent separation of caller and talent voice
- 16 bit DSP technology
- Proprietary auto null algorithm, 50 dB null
- XLR input (mic/line switch)
- 3.5 mm line input
- XLR caller output
- 3.5 mm line output
- 3.5 mm headphone jack
- Send & Receive LEDs
- Guest Module remote control jack
- Auto answer/disconnect



# innkeeper PBX

Innkeeper PBX easily converts your multi-line PBX type telephone system into a professional, affordable talk show console. Simply connect between your telephone handset and the phone base. So simple, anyone can do it.

**Talk Show:** Connect innkeeper PBX between your console and your existing multi-line telephone. Your producer can screen callers from another phone while you take callers on the air by simply selecting available lines on your phone.

**Interviews:** Use innkeeper PBX in your newsroom to record high quality interviews. Connect a mic and headphones to your PBX telephone while maintaining excellent separation between your voice and the caller.

**Conference Room:** Easily connect your PA system to the existing PBX telephone system. The echo canceller algorithm can prevent feedback and allow full duplex conversations.

The digital hybrid connects audio signals to your PBX type telephone system through the telephone handset cord. The Digital Signal Processor (DSP) continuously monitors both transmit and receive audio signals to deliver



excellent separation. This proprietary, dual-convergence echo canceller algorithm can achieve excellent separation without any setup, and without sending a noise burst down the line.

Innkeeper PBX provides connections for a microphone, headphones, mixer, sound card, and telephone handset. The stereo output

jack on the back of the unit provides your voice on one channel and only the caller's voice on the other channel. The balanced XLR output jack contains only the caller's voice. The Handset and Broadcast buttons select between talking on the handset, or sending and receiving through the audio connections.

**Price: \$495.00 US**

## Specifications

### Input

Mic/Line: Balanced Female XLR, 1kohm, 15 mV RMS (-34dBu) nom

Mic/Line pad switch: Line = +6 dBu max

Line: 3.5 mm, 20k ohms, 250 mV RMS (-10 dBu) nom

### Output

Balanced: Male XLR, 200ohm, 500 mV RMS (-4dBu) nom. +14 dBu max

Unbalanced: 3.5 mm stereo, 50 ohms, 250 mV RMS (-10dBu) nom. +6 dBu max  
Left = send, Right = caller

Headphone: 3.5 mm stereo, 8 ohms, 250 mW, mixed send and receive

Handset: RJ22

Phone Base: RJ22

Handset Type: Switch selects electret, dynamic, or carbon handset microphone types.

Isolation: 1500 VAC

Frequency Response: Telephone Side 200 Hz-3600 Hz

Power: 120-240 VAC power supply (included).

Size: 7" x 6" x 1.6" (18 x 15 x 4.2 cm)

Weight: 2.2 pounds (1 kg)

## Features

- Excellent separation of caller and talent voice
- 16 bit DSP technology
- Proprietary auto null algorithm
- XLR input (mic/line switch)
- 3.5 mm line input
- XLR caller output
- 3.5 mm line output
- 3.5 mm headphone jack
- Send & Receive LEDs
- Switch selects between electret, dynamic, and carbon handset types



# PBXport

PBXport is a professional digital hybrid capable of providing talk show quality caller audio from your PBX phone system. PBXport allows you to send mic or line level signals into your PBX telephone system while maintaining excellent separation between your voice and the caller. The balanced XLR output jack contains only the caller's voice allowing full duplex voice conferencing through the existing PBX phone system without fear of echo and feedback.

**Conference Room:** Easily connect your PA system to the existing PBX telephone system. The echo canceller algorithm can prevent feedback and allow full duplex conversations.

**Talk Show:** Connect PBXport between your console and your existing multi-line telephone. Your producer can screen callers from another phone while you take callers on the air by simply selecting available lines on your phone.

The digital hybrid connects audio signals to your PBX type telephone system through the telephone handset cord. The Digital Signal Processor (DSP) continuously monitors both transmit and receive audio signals to deliver excellent separation. This proprietary, dual-convergence echo canceller algorithm can achieve excellent separation without any setup, and without sending a noise burst down the line.

PBXport provides connections for a microphone, headphones, mixer, telephone hand-

set and your telephone set. Simply disconnect the handset coily cord from the base of your telephone, and connect this handset cord to the front or rear panel jacks on PBXport. Now connect the supplied cord from PBXport to your telephone base. The handset is disconnected when you press the "Online"

button, and reconnected when you press the "Handset" button.

The Handset Type switch allows PBXport to emulate the type of microphone found in any PBX phone system; electret, dynamic, or carbon handset microphones.

**Price: \$825.00 US**

## Specifications

### Input

Mic/Line: Balanced Female, XLR, 1 kohm, 15 mV RMS nom. (-34 dBu nom.)

Mic/Line pad switch: Line = +6dBu nom.

### Output

Caller, Mix: XLR, 200ohms balanced, 500 mV, RMS nom. (-4 dBu nom.) +12 dBu max

Headphone: 1/4" stereo, 8 ohms, 250 mW

Speaker: Screw terminal, 8 ohm, 1W max.

Handset: RJ22

Phone Base: RJ22

Handset Type: Switch selects electret, dynamic, or carbon handset microphone types

Isolation: 1500 VAC

Frequency Response: Telephone Side 200 Hz-3600 Hz

Screw Terminals: Speaker +  
Speaker -  
Ground  
Online LED  
Disconnect (N.O. remote control input)  
Connect (N.O. remote control input)

Power: 100-240 VAC 50-60 Hz

Size: 1.75" x 7.3" x 19"  
(4.5 x 18.6 x 48.3 cm)

Weight: 5.4 pounds (2.4 kg)

## Features

- 16 bit DSP Echo Canceller
- Proprietary auto null algorithm, 50 dB null
- Transmit female XLR with mic/line switch
- Caller output male XLR
- Mix output male XLR (adjustable mix of send & receive)
- Front panel 1/4" headphone jack
- Speaker output terminals
- Transmit and Receive LEDs
- Switch selects between electret, dynamic, and carbon handset types
- Front and Rear panel Handset and Phone Base RJ22 jacks
- Remote control screw terminal block



# RIU-IP Remote IP Interface

The RIU-IP is a remote control interface designed for innkeeper 1x, 1rx, 2 and 4 digital hybrids. This unit contains a web server which allows the user to send and receive control data through their web browser. RIU-IP can be connected to the user's computer NIC card for direct control, to a switch or hub for network control, or to an ethernet port with internet access for control from anywhere in the world.

**Price: \$345.00 US**

4-line screen version shown

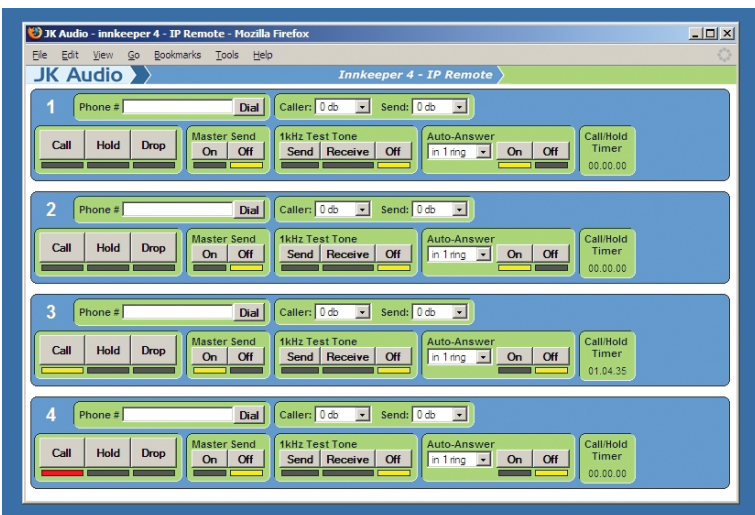

## Remote Control Capabilities

- Indication of incoming ring per line
- On-Hook and Off-Hook
- Confirmation of Off-Hook on On-Hook transition per line
- Place call on hold or release hold
- Dial (number) (line)
- Start and stop Conference (innkeeper 2)
- Adjust transmit and receive level per line (innkeeper 2 and 4)
- Auto-Answer on/off
- Auto-Answer ring count (innkeeper 2 and 4)
- Test tone start / stop per line
- Address book upload / download (innkeeper 2 and 4)
- Master Send configuration (innkeeper 2 and 4)
- Presence on/off (innkeeper 1x)
- Caller Ducking on/off (innkeeper 1x)
- Automatic Gain Control on/off (innkeeper 1x)

## Features

- Connects to innkeeper 1x and 1rx, innkeeper 2 or innkeeper 4 Digital Hybrids
- RJ45 Ethernet port
- RS-232 remote control port with simple ASCII protocol
- No external power required

## Specifications

Control connection:	RJ-45 Ethernet port
Digital Hybrid connection:	RJ-50
RS-232 Serial connection:	DB9 (9600,8,N,1)
Size:	5" x 3.25" x 1.125" ( 13 x 9 x 3 cm)
Weight:	1 lb (450 grams)

Designed for use with innkeeper 1x and 1rx and innkeeper 2 and 4



innkeeper 1x



# innkeeper 1x and 1rx



The innkeeper 1x gets audio in and out of analog telephone lines. Its excellent caller audio output does not exhibit the transmit/receive crosstalk common to analog hybrids. This makes innkeeper 1x perfect for radio or television talk shows, teleconferencing, or auto-answer IFB feeds.

Innkeeper 1x connects audio signals to a standard analog telephone line without the variations in quality found with analog hybrids. The main function of a hybrid is to bring in the caller's voice from the phone line, as clear and clean as possible. In the real world, when you send your voice down the telephone line it has a tendency to bleed over into the caller's audio. The hybrid must adapt to the phone line in order to properly separate transmit and receive audio. We use a 16-bit DSP to monitor the phone line and audio signals continuously in order to deliver excellent separation. Our dual-convergence algorithm can

achieve trans-hybrid loss, typically exceeding 50 dB, without any setup.

From the front panel you can control on-hook/off-hook, and adjust headphone volume. Front-panel LEDs display signal levels and option status. The Send and Caller Volume controls are hidden behind an access panel to discourage unauthorized "tweaking". Five feature switches are also hidden behind the access panel. AGC (Automatic Gain Control) adjusts the caller volume to an average level. AGC will tame a loud caller, and boost a quiet caller or quiet long distance connection. Caller Ducking drops the Caller output level by 9 dB whenever the host speaks. This keeps the host "in charge" of the show, automatically making sure the caller never overpowers the host by attempting to talk over the host's voice. Press the "Presence" button and you'll get a richer sound from the caller's voice. This

digital filter brings back some of the low-end lost in transmission. The Test Tone generator sends a 1 kHz full level tone either down the phone line or out the Caller XLR jack. This tone represents the maximum level transmit into the phone line or out the XLR jacks. The Test Tone generator is not required for tuning the digital hybrid. Auto-Answer simply answers on the first ring and disconnects at the end of the call.

This wouldn't be a JK Audio product without its fill of common-sense features. Check out the front-panel headphone jack and volume control. You can monitor either the send signal, the caller's voice, or a mix of the two. This output is also sent to the rear panel screw terminals so you can easily add a monitor speaker. As a matter of fact, several remote control connections can be found on real screw terminals for ease of installation. Three balanced audio connections:

Remote Keypad

# Guest Module 1



Guest Module 1 gives you remote access to the on-hook/ off-hook and dial features of the Broadcast Host and innkeeper 1 series digital hybrids. This little time-saver gives you call control you simply can't get with an auxiliary telephone and a couple of switches. Connect Guest Module 1 to your Broadcast Host and innkeeper 1 series digital hybrid using an 8 pin RJ45 modular cable. This cable provides remote power so there is no need for batteries or an external power pack. The Call button will flicker when a call comes in. Press this button to answer or place a call. The button will stay lit when a call is present. When you dial on-air, the tones go out on the line, and do not come back mixed with the dial tone or caller signal. Guest Module 1 was designed exclusively for

JK Audio Broadcast Host and innkeeper 1 series digital hybrids.

**Price: \$139.00 US**

**Specifications**

Size: 4.5" x 4" x 2"  
(11.4 x 10.1 x 5.1 cm)  
Weight: 12 ounces (240 grams)

**Features**

- DTMF keypad
- Keypad disable switch
- Talk/Dial Button
- Hangup Button
- Ring/Call LED



## innkeeper 1rx



mic/line switchable XLR input, XLR caller output and an additional, user-defined XLR output. And possibly the coolest feature: the innkeeper 1x can be remote controlled by either the optional Guest Module 1, the RIU-IP remote interface, or the included RS-232 cable. The Guest Module 1 allows remote Call, Drop, and DTMF dialing while the RIU-IP allows control of all functions of the innkeeper 1x through your web browser whether it is directly connected to your computer or via the internet from around the world. The RS-232 cable allows similar control using simple ASCII commands.

**Price: innkeeper 1x      \$795.00 US**

**Price: innkeeper 1rx     \$875.00 US**

### Specifications (for innkeeper 1 series)

<b>Input</b>	
Mic/Line:	Female XLR, 1k ohms, 15 mV RMS
<b>Output</b>	
Caller Out:	Male XLR 200 ohms, 500 mV RMS (-4dBu) nom. +12 dBu max
Mix Out:	Male XLR 200 ohms, 500 mV RMS (-4dBu) nom. +12 dBu max
Headphone:	1/4" Stereo 8 ohms, 250 mW per ch
Speaker:	Screw Terminals 8 ohms, 1 watt
Phone Line Connector:	RJ11C
Isolation:	1500 VAC
Ringer:	0.8B REN
Frequency Response, Telephone Side:	200 Hz–3600 Hz
Universal AC power input:	(120–240 VAC, 50–60 Hz)
Size:	1x – 1.75" x 7.3" x 10.5" (4.5 x 18.6 x 26.7 cm)
Weight:	1x – 5.2 lbs, (2.4 kg)
Size:	1rx – 1.75" x 7.3" x 19" (4.5 x 18.6 x 48.3 cm)
Weight:	1rx – 5.7 lbs, (2.6 kg)

### Features

- Excellent separation of caller and talent voice
- 16-bit DSP technology
- Proprietary auto null algorithm, 50 dB null
- Balanced XLR mic/line input
- Balanced XLR caller output
- Balanced XLR user-defined output
- Front-panel headphone jack
- Monitor speaker terminals on back
- Voice Presence Compensation
- Input/output LEDs
- Remote control screw terminals
- Remote control jack for Guest Module, RS-232 or optional IP remote
- Auto answer/disconnect
- AGC, Presence, Ducking, Tone Generator

## About Digital Hybrids

### Digital Hybrid

The purpose of a hybrid is to allow you to send and receive audio through a telephone line. The quality of the hybrid determines the amount of transmit audio that appears on the receive output jack, mixed with the caller's voice. We use a proprietary dual-convergence

echo canceller algorithm which continuously compares transmit and receive audio while building a model of the phone line. The first model is built within the first 200 milliseconds of the call. Afterwards, the algorithm continuously adapts to the phone line for the duration of the call. This system is not disturbed by changes

such as someone taking an extension phone off-hook. Only your audio source is used as input to the algorithm. It does not require any noise bursts or "quiet time" to complete its mission. Bottom Line... Excellent separation all the time.

## innkeeper 2



# innkeeper 2 and 4

Innkeeper 2 and innkeeper 4 squeeze two or four independent digital hybrids (respectively) into a 1U rack space. The front panel keypad, display, and handset jacks provide easy speed dialing and call setup. Digital hybrids allow you to send signals into the phone line while maintaining excellent separation between your voice and the caller. The balanced XLR output jacks contain only the caller's voice.

Digital hybrids connect audio signals to standard analog telephone lines without the transmit/receive crosstalk common to analog hybrids. The Digital Signal Processor (DSP) continuously monitors both the phone line and audio signals to deliver excellent separation. This proprietary, dual-convergence echo canceller algorithm can achieve excellent separation, typically exceeding 50 dB, without any setup and without sending a noise burst down the line.

The menu driven keypad and back lit display allow you to store 50 phone numbers by name in a phone list. You can also use the display to set features such as the number of rings before auto answer, master send channel selection, and test tone output. An auxiliary telephone jack is provided for each line. The auxiliary telephone is disconnected when you press the "Call" button, and reconnected when you press the "Drop" button.

Innkeeper 2 and 4 feature Auto-Answer/Auto Disconnect for use in IFB and monitoring applications. Other applications include: telephone interviews, talk shows, church PA interface, and conference room full duplex applications.

**Price: innkeeper 2 \$1,495.00 US**

**Price: innkeeper 4 \$1,795.00 US**

## Specifications

### Input

Line: (5) Balanced Female XLR, 20k ohms, 500 mV RMS (-4dBu) nom. +10 dBu max

### Output

Balanced: (4) Balanced male XLR, 200 ohms, 500 mV RMS (-4dBu) nom. +10 dBu max

Handset: Front panel handset jacks biased for electret handset (not included)

Phone Line: (4) RJ11C

Aux Phone: (4) RJ11C

Isolation: 1500 VAC

Ringer: 0.8B REN

Frequency Response: Telephone Side  
200 Hz–3600 Hz

Power: 120-240 VAC power supply (internal)

Size: 19" x 7.3" x 1.75"  
(4.5 x 18.6 x 48.3 cm)

Weight: 7.2 pounds (3.2 kg)

## Features

- Excellent separation of send and receive audio
- Memory/Speed Dial from phone list
- 16 bit DSP technology
- Proprietary auto null algorithm, 50 dB null
- XLR line input, one per line
- XLR master input sends audio to selected lines
- XLR caller output, one per line
- Send & Receive level LED
- Remote control and LED status indication
- Monitor Handset Jacks
- Auto answer/disconnect



## innkeeper 4



## Functions of the innkeeper 2 and 4

### Master Send



Each phone line has an individual send and receive XLR jack. While this should be enough for most applications, there are several applications that require a "Master" audio input. This additional XLR input mixes with the audio of the individual channel send jack. By default, the master input will mix into all four channels. The front panel menu system allows you to turn off the master signal from any or all phone lines.



### Keypad Dialing

Don't let the display and cursor keys scare you. If you need to place a call, just press the Call button on any line, then start dialing. To "hang up" simply press Drop.

### Remote Control



Included with your innkeeper 4 is a small terminal board with a 5 foot cable that attaches to the remote jack on the back panel. This terminal block contains two pins for each phone line. One pin provides Off Hook indication which supplies current to a remote LED when the line is active. The second pin is for a remote toggle switch to take the corresponding line off or on hook.

This remote jack also connects to our model RIU-IP web server providing remote control from anywhere in the world.

### Menu System

The cursor keys guide you through several features including speed dialing, test tone generation, Auto-Answer ring count, and Master Send line muting. Speed dial list includes phone numbers referenced by an alpha text name such as "Bob Smith". Test tone generation allows you to send a 1 kHz signal down any phone line or out any Caller output jack. This signal allows you to set levels on your existing audio equipment. Test signals are not a part of the auto-null tuning algorithm. Auto-Answer can be set to pick up after 0-7 rings (0 = never answer).

### Innkeeper 2 Conferencing

Innkeeper 2 has a convenient conference feature that joins two active phone calls together. Menu options determine how the conference is joined, providing several options to ease mix-minus setup.



# ComPack

Pick up this handheld road tool to get audio in and out of analog phone lines, PBX systems, even cell phones. Perfect for Remote Broadcasts, IFB feeds, or interviews over any phone connection.

**Cell Phones:** Simply plug ComPack into the 2.5 mm headset jack of your wireless cell phone. Your phone will recognize ComPack as a headset, allowing you to send and receive audio through the phone.

**PBX Systems:** Unplug the handset from any analog or digital PBX phone and plug the coily cord into ComPack. You can now send and receive audio through the PBX telephone set.

**Analog Phones:** Plug ComPack into an RJ-11 jack, go off-hook and dial, or answer an incoming call.

ComPack also functions as a simple telecom interface for your beltpack intercom system. This no-frills feature allows you to connect the 3 pin male XLR to your beltpack intercom group. This provides a full duplex, always-on connection to any telephone network.

The ComPack cell phone interface was designed to take advantage of the increasing number of wireless phones that accept third party headsets and earpiece headsets. Please see Wireless Phone Compatibility on page 2.

**Price: \$545.00 US**

## Specifications

<b>Input</b>	
XLR Female:	1 kohm, 15 mV RMS (-34dBu) nom
Mic/Line pad switch:	Line = +6 dBu max
Line Input (3.5 mm):	20 k ohms, 250 mV RMS (-10 dBu) nom
<b>Output</b>	
Male XLR	
Mix Output:	600 ohms balanced phone mix output 45 mV RMS (-25dBu) nom
Intercom mode:	Pin 3 bidirectional unbalanced
Headphone:	1/4" stereo, 8 ohms, 500 mW
Phone Line:	RJ11C
Isolation:	1500 VAC
Ringer LED:	0.9B REN
Keypad:	DTMF
PBX Handset interface	simulates electret, dynamic, and carbon handset microphone types
Wireless phone:	36" cable provided with 2.5 mm, 3 conductor headset plug.
Power:	One 9 volt battery, AC power supply 120-240 VAC (included)
Size:	8" x 3" x 2.2" (20.3 x 7.6 x 5.6 cm)
Weight:	1.5 pounds (680 grams)
Shoulder strap included.	

## Features

- XLR input (mic/line switch)
- 3.5 mm line input
- 1/4" headphone jack
- Works with conventional phone lines
- Works with analog and digital PBX or ISDN phones
- Works with most wireless phones
- XLR phone mix output switches to intercom link
- Transmit clip LED
- Battery test LED
- Keypad lockout switch
- Runs 20 hours on one 9 volt battery



High quality audio connectors clearly labeled for quick setup.

# RemoteMix C+

The RemoteMix C+ is a combined audio mixer, headphone amplifier and telephone hybrid in one! It's perfect for remote broadcasts, sporting events, and field reporting from any location.

Simply plug the RemoteMix C+ into an analog phone line, connect a couple of microphones and headphones, and you're ready to call into the station. Switch the "Phone Line" switch to "Dial/Talk" and you will hear a dial tone. Now dial using the RemoteMix C+ tone keypad. In your headphones, you will hear a mix of both microphones and the line in jack, as well as the audio coming back from the other side of the phone call. This headphone mix also comes out of the back of the unit on an RCA jack and on an XLR balanced jack, which are adjustable from line level to mic level for PA system or tape deck feeds. The built-in time-delayed peak limiter helps to control transmit levels.

Remote broadcasts over a cell phone? Check out our Daptor One wireless phone adapter. This new accessory connects between the RemoteMix C+ phone line jack and the 2.5 mm headset jack on your wireless phone.

**Price: \$595.00 US**

## Specifications

### Input

Microphone: (2) Female XLR 1 kohm, 15 mV RMS (-34dBu) nom  
 Mic 1 has a Mic/Line pad switch, Line = +6 dBu max  
 Line In: RCA 50k ohms, 250 mV RMS (-10 dBu) nom

### Output

Line Out: RCA 250 mV RMS (-10dBu) nom. +5 dBu max  
 Balanced Out: Male XLR 200 ohms, 500 mV RMS (-4dBu) nom. +12 dBu max  
 Headphones: (2) 1/4" Stereo 8 ohms, 1/2 watt per channel  
 Phone Line Connector: RJ11C  
 Isolation: 1500 VAC  
 Ringer: 1.2B REN  
 Keypad: DTMF (Dual Tone Multi Frequency)  
 Aux Handset Jack biased for electret microphone type handset.

Size: 6.5" x 4.6" x 2.2"  
 (16.5 x 11.7 x 5.6 cm)  
 Weight: 1.8 pounds (820 grams)

## Features

- Two XLR microphone inputs
- Two 1/4" headphone jacks
- RCA line in and out
- Works with conventional phone lines
- Works with cell phones using optional Daptor One interface
- XLR balanced mix output
- Mic / line switch on Mic 1
- Runs 36 hours on two 9-volt batteries or AC adapter (included)
- DTMF/pulse keypad
- Auxiliary handset input for use as a standard telephone



High quality audio connectors clearly labeled for quick setup.



Universal PBX interface with 3 position handset type switch.

# RemoteMix 3

The RemoteMix 3 is a combined Phone Line Hybrid Mixer and Universal Handset Interface in one! We combined an audio mixer, headphone amplifier, telephone hybrid, and PBX telephone interface in one rugged unit. It's perfect for remote broadcasts, sport events, and field reporting from any location.

Simply plug the RemoteMix 3 into an analog phone line, connect a couple of microphones and headphones, and you're ready to call into the station. In your headphones, you will hear a mix of both microphones and the line in jack, as well as the audio coming back from the other side of the phone call. This headphone mix also comes out of the back of the unit on an RCA jack and an XLR balanced jack, which are adjustable from line level to mic level for PA system or tape deck feeds. The built-in time-delayed peak limiter and VU meter help to control transmit levels, while the built-in push-to-talk condenser microphone and monitor speaker are a real help during equipment set-up and station breaks.

## Universal Handset Interface?

Did you ever get to a remote site where the location manager hands you a PBX telephone and says "Here's your phone, use line 3....". Well, now you can! Simply unplug the handset from the phone and plug the coily cord directly into the PBX jack on the RemoteMix 3, then select the type of handset that was on the phone. The

RemoteMix 3 has a 3 position switch which will accommodate electret, dynamic, and carbon handset microphone types. It will emulate the type of microphone that was in the handset and allow you to use your professional microphones and headphones during the broadcast. Its three settings cover most analog and digital PBX sets as well as ISDN sets.

**Price: \$895.00 US**

## Specifications

### Input

Microphone: (2) Female XLR 1 kohm, 15 mV RMS (-34dBu) nom  
 Mic 1 has a Mic/Line pad switch, Line = +6 dBu max  
 Line In: RCA 50k ohms, 250 mV RMS (-10 dBu) nom

### Output

Line Out: RCA 50 ohms, 250 mV RMS (-10dBu) nom. +5 dBu max  
 Balanced Out: Male XLR 200 ohms, 500 mV RMS (-4dBu) nom. +12 dBu max  
 Headphones: (2) 1/4" Stereo 8 ohms, 1/2 watt per channel

Phone Line Connector: RJ11C  
 Isolation: 1500 VAC  
 Ringer: 1.2B REN  
 Keypad: DTMF (Dual Tone Multi Frequency)

Auxiliary Handset Jack, biased for electret microphone type handset.

PBX Handset Interface biased for Electret, Dynamic, and Carbon handsets.

Size: 6.5" x 4.6" x 2.2"  
 (16.5 x 11.7 x 5.6 cm)

Weight: 2.2 pounds (1 kg)

## Features

- Two XLR microphone inputs
- Two 1/4" headphone jacks
- RCA line in and out
- Works with conventional phone lines
- Works with analog and digital PBX or ISDN phones
- Works with cell phones using optional Daptor One interface
- XLR mixer/phone mix output
- Transmit VU meter
- Mic/line switch on Mic 1
- Built-in monitor speaker and talk-back microphone
- Runs 36 hours on two 9-volt batteries or AC adapter (included)
- DTMF/pulse keypad
- Keypad lockout switch
- Auxiliary handset input for use as a standard telephone



With 3 balanced inputs and 3 headphone outputs the RemoteMix Sport is ready for coverage of ANY sporting event that utilizes multiple commentators.

Universal PBX interface with 3 position handset type switch.



# RemoteMix Sport

The RemoteMix Sport takes the great features of our RemoteMix 3 and adds a third microphone and headphone jack and more. Sports broadcasters asked, and we delivered. We combined an audio mixer, headphone amplifier, telephone hybrid, and PBX telephone interface in one rugged unit that's perfect for remote broadcasts, sporting events, and field reporting from any location.

Simply plug the RemoteMix Sport into an analog phone line, connect up to three microphones and headphones, and you're ready to call into the station. In your headphones you will hear a mix of all three microphones, as well as the audio coming back from the other side of the phone call. You can also listen to any signal connected to the line level Headphone Cue Input jack. The line level male XLR output includes a switch which selects either a clean mic mix output or the phone line return + mic mix combination. The combination of this clean mic-only output and the new headphone cue input makes RemoteMix Sport perfect for use as a front end mixer for your POTS or ISDN codec. The built-in time-delayed peak limiter and VU meter help to control transmit levels, while the built-in push-to-talk condenser microphone and monitor speaker are a real help during equipment set-up and station breaks.

## Universal Handset Interface?

Did you ever get to a remote site where the location manager hands you a PBX telephone and says "Here's your phone, use line 3...?" Well, now you can! Simply unplug the handset from the phone and plug the coily cord directly into the PBX jack on RemoteMix Sport. With

a three-position switch which accommodates electret, dynamic, and carbon handset microphone types, the RemoteMix Sport emulates the type of microphone that was in the handset, allowing you to use your professional microphones and headphones during the broadcast. Its three settings cover most analog and digital PBX sets, as well as ISDN sets.

Cell phones: Simply plug RemoteMix Sport into the 2.5 mm headset jack of your wireless cell phone. Your phone will recognize RemoteMix Sport as a headset, allowing you to send and receive audio through the phone. Please see Wireless Phone Compatibility on page 2.

**Price: \$995.00 US**

## Specifications

### Input

Microphone: (3) Female XLR, 1 kohm, 15 mV RMS (-34dBu) nom  
 Mic 1 has a Mic/Line pad switch, Line = +6 dBu max  
 Headphone Cue in: 1/4" 50 ohms, 250 mV RMS (-10 dBu) nom

### Output

Balanced out: Male XLR, 200 ohms, 500 mV RMS (-4dBu) nom. +4 dBu max  
 Headphones: (3) 1/4" Stereo, 8 ohms, 1/2 watt per channel  
 Phone line: RJ11C  
 Isolation: 1500 VAC  
 Ringer: 0.9B REN  
 Keypad: DTMF (Dual Tone Multi Frequency) Pulse switchable

Auxiliary Handset Jack, biased for electret microphone type handset.

PBX Handset Interface biased for Electret, Dynamic, and Carbon handsets.

Size: 6.5" x 4.6" x 2.2"  
 (16.5 x 11.7 x 5.6 cm)

Weight: 2.5 pounds (1.2 kg)

## Features

- Three XLR microphone inputs
- Three 1/4" headphone jacks
- 1/4" headphone cue input
- Works with conventional phone lines
- Works with analog and digital PBX or ISDN phones
- Works with most wireless phones
- XLR clean mix or phone mix output
- Transmit VU meter
- Mic/line switch on Mic 1
- Built-in monitor speaker and talkback microphone
- Runs 28 hours on two 9-volt batteries or included AC adapter
- DTMF/pulse keypad
- Keypad lockout switch
- Auxiliary handset input for use as a standard telephone



# Daptor One

Remote Broadcasts over a cell phone? Daptor One converts the 2.5mm headset jack on your wireless cellular phone to a modular phone line jack. This modular RJ11 jack connects directly to any JK Audio RemoteMix series mixer or any JK Audio innkeeper 1x Digital Hybrid.

Daptor One was designed to take advantage of the increasing number of wireless phones that accept third party headsets and earpiece headsets. We've designed a circuit which emulates the electrical characteristics of these headsets. Daptor One will work with all wireless phones that accept generic third party headsets. Please see Wireless Phone Compatibility on page 2. Daptor One contains a mini hybrid circuit that converts these earpiece and microphone signals into a balanced RJ11 phone line signal. The mic signals from the RemoteMix are sent into the wireless phone, while the earpiece signals from the wireless phone are sent into the RemoteMix Headphones. The hybrid circuit minimizes cross

talk between transmit and receive which would create unwanted echo on both the RemoteMix and far side of the call. You will continue to use your wireless phone to dial or answer the call, but you will use the microphones and headphones plugged into your RemoteMix during the call.

Daptor One does not supply the necessary ring voltage or talk battery which may be required by modems or other manufacturer's remote consoles.

**Price: \$119.00 US**



## Specifications

Phone Line Jack:	RJ11C
Headset Jack:	1/4" TRS (36" cable, 1/4" to 2.5 mm provided)
Size:	3.6" x 1.6" x 1.3" (9.2 x 4.1 x 3.3 cm)
Weight:	6 ounces (170 grams)

## Features

- Works with many wireless phones
- Hybrid circuit minimizes echo
- No battery or AC needed
- Durable diecast aluminum construction



# Daptor Two

Remote Broadcasts or IFB feeds over a cell phone? Simply plug Daptor Two into the 2.5 mm headset jack of your cell phone. You can now send and receive audio from your mixer or tape recorder through the phone. Your cell phone will recognize Daptor Two as a headset which will disable the mic and speaker in the phone.

Daptor Two was designed to take advantage of the increasing number of wireless phones that accept third party headsets and earpieces. We've designed a circuit which emulates the electrical characteristics of these headsets. Please see Wireless Phone Compatibility on page 2.

Audio Connections—You may use either the XLR input or 1/4" input, not both. The XLR input jack is disconnected when a cable is plugged into the 1/4" input jack. The same is true for the XLR and 1/4" output jacks.

**Price: \$175.00 US**



## Specifications

### Inputs

XLR:	600 ohms balanced, 250 mV RMS (-10 dBu) nom. 0 dBu max
1/4":	mono 600 ohms unbalanced, line level, 600 ohms, 250 mV RMS (-10 dBu) nom. 0 dBu max

### Outputs

XLR:	600 ohms balanced, mic level, 45 mV RMS (-25dBu) nom
1/4":	mono, unbalanced, mic level, -45 mV RMS (-25dBu) nom
Phone:	36" cable provided with 2.5 mm, 3 conductor headset plug
Power:	Passive, no AC or battery power needed
Size:	4.4" x 2.7" x 1.2" (11.2 x 6.9 x 3.5 cm)
Weight:	7 ounces (200 grams)

## Features

- XLR and 1/4" in and out
- Passive, no AC or battery power needed
- Rugged diecast aluminum construction



# CellTap



Need to record your cell conversations? Connect CellTap between the 2.5 mm earpiece jack of your cell phone and your earpiece or headset. Now connect a tape recorder or powered speakers to the 3.5 mm mini jack. This audio output contains a nice mix of both sides of the conversation.

CellTap works with most wireless phones that accept a third party headset or earpiece.

Group Listen—Simply connect a powered speaker to the audio output jack and you will have a new conferencing capability. Everyone in the room can hear your conversation, but only the person wearing the headset can talk to the distant party. While this is not a speakerphone, in many cases it is more suitable for sales presentations or contract talks. Please see Wireless Phone Compatibility on page 2.

**Price: \$79.00 US**

## Specifications

- 3.5 mm mono audio output jack:  
600 ohms, 100 mV RMS (-18 dBm) nom.
- 2.5 mm headset jack:  
36" cord with 2.5 mm headset plug provided
- Power: Passive, no AC or battery power needed.
- Size: 2" x 2" x 1.3" (5.1 x 5.1 x 3.3 cm)
- Weight: 3.5 ounces (100 grams)
- Included: One 60" cable, 3.5 mm mono male to 3.5 mm mono male

## Features

- 3.5mm audio output
- Passive, no AC or battery power needed
- Rugged diecast Aluminum



# VoicePath



Voice Path routes the audio from any telephone into your PC sound card. Simply connect between the handset and base of your telephone. The attached cables connect directly to the in and out jacks of your sound card. Use your PC software to record, edit, and then play your conversation right back into the phone line.

Endless possibilities such as: News rooms, Weather and Traffic reports, Ad Creation and Proofing, Transcribing, Voice Mail Prompts, Production Room...

Once installed, Voice Path continuously routes both sides of your conversation to the mic input of your PC (or Mac) sound card. Simply press in the gray button when you are ready to play audio recordings back into the phone line. With the button in, Voice Path will disconnect the microphone from your handset and send audio down the phone line and into your receiver. You will hear the transmit audio as well as the voice from the other end of the call.

When sending audio into a telephone, Voice Path must emulate the microphone that is in the handset. A switch on the back of Voice Path allows you select between the three basic types of handset microphone: electret,

dynamic, and carbon. Signal level to the PC sound card is also adjustable.

Voice Path will not work with telephones that have a keypad in the handset.

**Price: \$109.00 US**

## Specifications

- Handset: 4 pin/4 position handset jack
- Phone Base: 4 pin/4 position jack
- Handset Cable: 18" flat cable (provided)
- Audio input: 3.5 mm stereo plug, 48" long, left channel only, 10k ohms, 250 mV RMS (-10 dBu) nom
- Audio output: 3.5 mm mono plug, 48" long cable, 2.8k ohms, 100 mV RMS (-18dBu) nom
- Size: 3" x 1" x 2" (7.6 x 2.5 x 5.1 cm)
- Weight: 9 ounces (260 grams)
- Included: One 18" cable, handset plug to handset plug

## Features

- Analog and digital phone systems
- Single or multi-line phones
- No Batteries or AC needed
- Simple operation, great sound

# QuickTap



Connect the QuickTap between your telephone and handset for quick access to audio from any telephone.

Simply unplug the handset coily cord from the base of your telephone and plug it directly into the QuickTap. Then, using the supplied cable, connect the QuickTap to the base of the telephone. Now connect your audio equipment or powered speaker to the audio output jack. This jack contains a nice mix of both sides of the conversation, as well as the tones being pressed on the keypad.

The QuickTap does not work with cellular telephones or any telephone with a keypad in the handset

**Price: \$59.00 US**

## Specifications

Line Output:	1/8" (3.5 mm) mono 600 ohms, 100 mV RMS (-18dBu) nom
Size:	2" x 2" x 1.3" (5.1 x 5.1 x 3.3 cm)
Weight:	3.4 ounces (100 grams)
Included:	One 18" cable, RCA male to 3.5 mm male One 60" cable, 3.5 mm mono male to 3.5 mm mono male One 18" cable, handset plug to handset plug

## Features

- Works with analog, digital, PBX, and ISDN telephones
- 1/8" mono audio out
- Use the QuickTap to get audio into a sound card or portable recorder
- Get presentation quality audio using a powered speaker or PA system
- No battery or AC adapter needed!
- Durable diecast aluminum construction

# THAT-1



Simply plug the THAT-1 between the handset and the base of your phone

Connect the THAT-1 between your telephone and handset for quick access to audio in and out of the telephone. The THAT-1 is used by radio stations to record and play sound bites, and by computer and telephone companies to demonstrate their computer voice services using a powered speaker.

Simply unplug the handset coily cord from the base of your telephone and plug it directly into the THAT-1. Then, using the supplied cable, connect the THAT-1 back to the telephone. Now connect your audio equipment or powered speaker using the RCA jacks. The gray pushbutton selects which audio will be sent into the telephone (OUT = talking on the handset, IN = sending audio in through the RCA jack). The output RCA jack contains a nice mix of the audio from both sides of the conversation, as well as the tones being pressed on the keypad. The volume control adjusts the volume of the signal going to your powered speaker or tape recorder.

The THAT-1 will work with many different types of analog and digital PBX and ISDN telephones. The receive side of the THAT-1 (audio From Phone), will work on any telephone. To send audio into the telephone (To Phone), the telephone must have an electret type microphone in the handset. If your telephone has a round mouthpiece or if you intend to use this product on many different telephones, you should consider our model THAT-2, which is compatible with more telephone systems.

The THAT-1 does not work with cellular telephones or any telephone with a keypad in the handset.

**Price: \$150.00 US**

## Specifications

Line Input	RCA 20 k ohms, 2.5k ohms nom., 250 mV RMS (-10 dBu) nom. +12 dBu max
Line Output	RCA 2800 ohms, 2.5k ohms nom., 100 mV RMS (-18dBu) nom
Handset Interface	biased for electret handsets
Size:	3.7" x 1.6" x 1.3" (9.4 x 4.1 x 3.3 cm)
Weight:	6.1 ounces (175 grams)
Included:	One 18" cable, RCA male to 3.5 mm male One 18" cable, handset plug to handset plug

## Features

- Works with analog, digital, PBX, and ISDN telephones
- RCA line in and out
- Use the THAT-1 to get audio in and out of a sound card
- Get presentation-quality audio using a powered speaker or PA system
- No battery or AC adapter needed!
- Durable diecast aluminum construction



# THAT-2

Connect the THAT-2 between your telephone and handset for quick access to audio in and out of the telephone. The THAT-2 is used by radio stations to record and play sound bites, and by TV and film sound crews to get IFB and dialog over phone lines.

The THAT-2 is the big brother of our model THAT-1, which is very popular with news reporters for its small yet rugged design. Over the years we've heard from many of our customers that they liked the THAT-1 but would prefer professional XLR jacks and compatibility with more telephone systems. Here is our answer... The THAT-2, a passive handset interface with professional and consumer jacks, separate input and output volume control, a selector switch for the different types of telephone systems, and still no batteries or AC needed!

Simply unplug the handset coily cord from the base of your telephone and plug it directly into the THAT-2. Then, using the supplied cable, connect the THAT-2 back to the telephone.

Now connect your audio equipment to the RCA or XLR jacks. The gray pushbutton selects which audio will be sent into the telephone (OUT = talking on the handset, IN = sending

audio in through the RCA or XLR jacks). The output jacks contain a nice mix of audio from both sides of the conversation as well as the tones being pressed on the telephone keypad. The THAT-2 has a three-position switch which accommodates electret, dynamic, and carbon telephone handset microphone types. The THAT-2 will emulate the type of microphone that is in the handset and allow you send audio into many different types of analog and digital PBX sets, as well as ISDN telephones. The THAT-2 does not work with cellular telephones or any telephone with a keypad in the handset.



Simply plug the THAT2 between the handset and the base of your phone

**Price: \$225.00 US**

## Specifications

### Line Input

RCA: 2.5k ohms nom., 250 mV RMS (-10 dBu) nom. +12 dBu max

XLR female: 2.5k ohms nom., 250 mV RMS (-10 dBu) nom. +12 dBu max

### Line Output

RCA: 2.5k ohms nom., 100 mV RMS (-18 dBu) nom

XLR male: 2.5k ohms nom., 100 mV RMS (-18 dBu) nom

Handset Interface: Biased for Electret, Dynamic, and Carbon handsets.

Size: 4.5" x 3.2" x 1.3" (11.4 x 8.2 x 3.3 cm)

Weight: 9 ounces (250 grams)

Included: One 18" cable, RCA male to 3.5 mm male  
One 18" cable, handset plug to handset plug

## Features

- Works with analog, digital, PBX, and ISDN telephones
- RCA and XLR line in and out
- Switch selects between carbon, dynamic, or electret handset types
- No battery or AC adapter needed!
- Durable diecast aluminum construction



# QuickTap IFB

Connect the QuickTap IFB between your telephone and handset for quick access to audio from any telephone system.

Simply unplug the handset coily cord from the base of your telephone and plug it directly into the QuickTap IFB, then, using the supplied cable, connect the QuickTap IFB to the base of the telephone. The 600 ohm male XLR lets you take audio from the phone line and route it into a mixer or headset amplifier. You can also plug an IFB earpiece directly into the 1/8" mini jack. But keep in mind this is a passive box with a 600 ohm output; the earpiece should have an impedance greater than 600 ohms to get usable output.

Both audio output jacks contain a nice mix of the audio coming from the phone line and the handset audio going into the phone. Any conversation over the handset is sent over both audio output jacks. Or you can leave the handset disconnected and just hear audio from the far end of the call. QuickTap IFB does not work with cellular telephones or any telephone with a keypad in the handset.



## Specifications

IFB Earpiece:	1/8" mono 600 ohm, 100 mV RMS (-18dBu) nom
Unbalanced Out:	XLR 600 ohm, 100 mV RMS (-18dBu) nom
Size:	3.7" x 1.6" x 1.3" (9.4 x 4.1 x 3.3 cm)
Weight:	5 ounces

## Features

- Works with analog, digital, PBX, and ISDN telephones
- 600 ohm 1/8" mono output jack with attenuator
- 600 ohm XLR male fixed output, -16 dBm avg
- No battery or AC adapter needed!
- Durable diecast aluminum construction

**Price: \$125.00 US**



# RemoteAmp

CE



The RemoteAmp is a simple battery-powered personal headphone amplifier.

Use the RemoteAmp as an IFB earpiece or headphone amplifier, or as an on-stage monitor headphone amplifier. This low-distortion, 1 watt amplifier will cut through the crowd noise without distortion.

The RemoteAmp clips to your belt and accepts a 3-pin XLR audio input from a mixer, distribution amplifier, telephone line hybrid, or a handset

interface like our QuickTap IFB. You'll like the convenience features, such as the separate power switch, which allows you to leave the volume control set at a comfortable level. And you'll appreciate the common-sense features like the battery test indicator and easy change battery door.

**Price: \$215.00 US**

## Specifications

<b>Line Input</b>	XLR female 4000 ohms, 100 mV RMS (-18dBu) nom. +12 dBu max, 46 dB maximum gain
<b>Output</b>	1/4" Stereo 8 ohms, 1 watt maximum 1/8" mono 150 ohms, 100 milliwatts nominal
Size:	5.1" x 2.7" x 1.3" (13 x 6.9 x 3.3 cm)
Weight:	10 ounces (280 grams)

## Features

- 1/4" 8 ohm headphone jack
- 1/8" 150 ohm earpiece jack
- Battery test indicator
- Easy change battery compartment
- Durable diecast aluminum construction
- Stainless steel belt clip



# Four IFB Multi-Line Phone Bridge

Four IFB is a four position analog telephone line interface designed specifically to provide flexible listen only IFB\* for television field production use. Each IFB output, and the monitor input / output jacks, may be separately connected to one of the four analog phone lines through the use of rotary line selector switches. A telephone handset may also be connected for communication with the Monitor phone line. Four IFB is designed to be used in a variety of environments and weather conditions. All controls and components are dust and moisture resistant. A non-removable hinged cover protects the unit's selector switches, add/drop buttons and keypad while the enclosure design protects the volume controls from physical damage.

**Price: \$ 1,495.00 US**



\*IFB is a broadcast industry acronym which stands for Interruptible Fold Back. The IFB signal is typically a Program Line (PL) signal from the studio console.

## Simplified Block Diagram

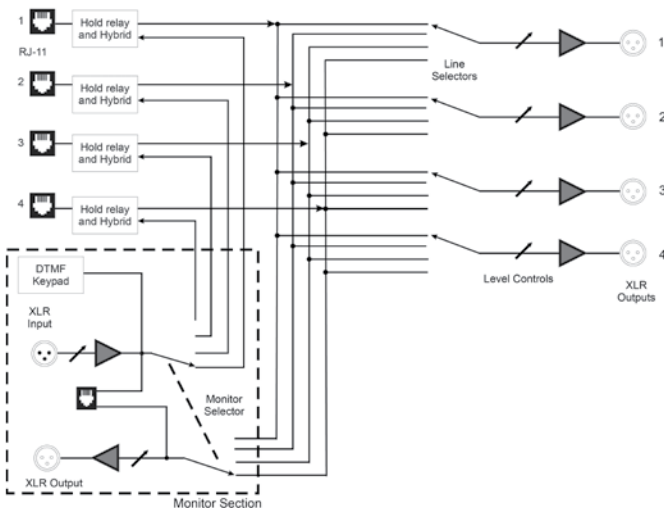

## Specifications

### Input

**Line:** Balanced Female XLR Line level, 20k ohms, +4dBu max

### Outputs

**Line:** 5 - Balanced Male XLR Line level, 600 ohms, +4 dBu max

**Handset:** RJ-22 handset jack biased for electret handset (not included)

**Phone Line:** 4 - RJ11C

**Isolation:** 1500 VAC

**Ringer:** 0.5B REN

**Frequency Response:** Telephone Side 200 Hz - 3600 Hz

**Power:** 120-240 VAC, 50-60 Hz internal power supply

**Auxiliary Power:** Single 9VDC battery

**Size:** 10" x 9.75" x 2" (26 x 25 x 5 cm)

**Weight:** 3.5 lbs (1.6 kg)



# Pureformer

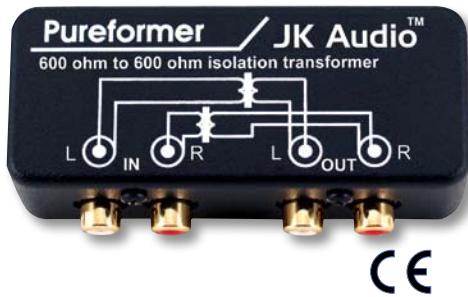

The Pureformer provides hum and noise reduction for sound cards and audio equipment, and removes ground loops and DC paths that can cause hum and signal breakup.

The Pureformer isolates the electrical grounds of two pieces of audio equipment. This is especially important in the case of computer audio cards connected to high quality/low noise audio equipment. The computer electrical ground is often filled with noise from disk drive activity and data transmission. Many audio cards use the same electrical ground for the computer and the audio

signal. When the computer audio card is connected to your studio equipment, the electrical noise from the computer can leak into the rest of your audio system.

The Pureformer completely isolates the electrical ground of the two systems and only allows audio signals to pass through. Pureformer cannot remove noise once it has been mixed with the audio signal, so it is important to find and treat the source of each problem.

**Price: \$59.00 US**

## Specifications

<b>Input</b>	(2) RCA 600 ohms, 250 mV RMS (-10 dBu nom)
<b>Output</b>	(2) RCA 600 ohms, 250 mV RMS (-10 dBu nom)
	Frequency Response: 20 Hz – 20 kHz ( $\pm$ ) 0.1 dB
	Insertion Loss: 0.8 dB
<b>Size:</b>	3.6" x 1.8" x 1.3" (9.2 x 4.6 x 3.3 cm)
<b>Weight:</b>	5 ounces (150 grams)
<b>Included:</b>	One 60" Stereo RCA-RCA cable

## Features

- Just insert between your sound card and your audio mixer or amplifier
- High-quality, low-distortion, 600 ohm audio transformers
- Durable diecast aluminum construction.



# TAP-1

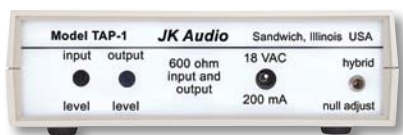

The TAP-1 is a phone line simulator for simple audio applications, that powers an analog telephone with the required -48 volts DC and separates audio into transmit and receive audio paths. The TAP-1 acts like an RJ-11 wall jack in your home. You may not know it, but the telephone company sends power down into your wall jack, and you use it to power your phone. This power is sent over the two wires called Tip and Ring. These two wires form a balanced, two-way voice path which can be sent miles with minimal noise and signal loss. This two-wire interface can be a burden if you just want to get audio in and out of a telephone without connection to the telephone company.

The TAP-1 provides the Tip/Ring interface and -48 volt supply and then separates audio into transmit and receive. This is called a 2-wire to 4-wire hybrid. The bottom line... the TAP-1 can be used on TV or film studio sets where a telephone or cordless telephone is used on set and you want to get audio into and out of the telephone. You can also use the TAP-1 to test telephones, voice coding algorithms, or phone line equipment. The TAP-1 is built to very high specs for laboratory testing use.

**Price: \$245.00 US**

## Specifications

<b>Line Input</b>	RCA 600 ohms, 250 mV RMS (-10 dBm nom)
<b>Bandwidth:</b>	60 Hz-15 kHz ( $\pm$ 3 dB), 120 Hz-8 kHz ( $\pm$ 1 dB)
<b>Line Output</b>	RCA 600 ohms, 250 mV RMS (-10 dBm nom)
<b>Bandwidth:</b>	180 Hz-12 kHz ( $\pm$ 3 dB), 300 Hz-6 kHz ( $\pm$ 1 dB)
<b>Phone Line AC Impedance:</b>	510 ohms
<b>DC series resistance:</b>	480 ohms
<b>DC Voltage:</b>	-48 VDC (open circuit)
<b>DC Current Max:</b>	70 mA (short circuit)
<b>Trans-Hybrid Loss:</b>	>50 dB at 1 kHz
<b>Power:</b>	18 VAC, 160 mA (120 VAC, UL approved transformer supplied)

<b>Size:</b>	5.1" x 5.2" x 1.6" (13 x 13.2 x 4.1 cm)
<b>Weight:</b>	1.3 pounds (600 grams)

## Features

- 600 ohm RCA line in and out
- Recessed input and output volume controls
- Hybrid null adjustment optimizes transmit and receive separation to >50 dB
- Put two units back-to-back or through a mixer for TV or film studio recording
- Put an analog telephone on your sound card for Internet Telephone use

### Internet Telephone?

You can also use the TAP-1 to power a cordless telephone and connect the audio paths to a sound card for use as an internet telephone. Imagine roaming the house as you talk over the internet.

## Product/Feature Comparison

Features	Bluetooth	Cell Interface	Phone Line	Universal Handset	Microphone	Phantom Power	XLR Line In	XLR Out	Headphones	Earpiece	RCA Line In	RCA Line Out	3.5 mm Line In	3.5 mm Line Out	AUX Handset	Battery	AC Power	Page Number
AutoHybrid			1				1	1										10
BluePack	✓	✓			1				1				1	1		✓		5
Broadcast Host			1		1		1*	1	1				1	1			✓	12
CellTap		✓								1				1				25
Compack		✓	1	✓	1		1*	1	1				1			✓	✓	20
Daptor Two		✓					1	1										24
Daptor Three	✓	✓					1	1					1	1		✓		7
Four IFB			4				1	5							1	✓	✓	29
Inline Patch			1				1	1					1	2			✓	11
Innkeeper 1rx			1		1		1*	2	1								✓	16
Innkeeper 1x			1		1		1*	2	1								✓	16
Innkeeper 2			2				3	2							2		✓	18
Innkeeper 4			4				5	4							4		✓	18
Innkeeper PBX				✓	1		1*	1	1				1	1			✓	13
PBXport				✓	1		1*	2	1								✓	14
Pureformer											2	2						30
QuickTap				✓										1				26
QuickTap IFB				✓				1		1								28
RemoteAmp							1		1	1						✓		28
RemoteAmp Blue	✓	✓					1		1	1			1			✓		4
RemoteAmp Two							1		1	1			1			✓		6
RemoteMix 3			1	✓	2		1*	1	2		1	1			1	✓	✓	22
RemoteMix 4	✓	✓	1	✓	4	✓	2*	1	4				1	1		✓	✓	8
RemoteMix C+			1		2		1*	1	2		1	1			1	✓	✓	21
RemoteMix Sport		✓	1	✓	3		1*	1	3						1	✓	✓	23
THAT-1				✓							1	1						26
THAT-2				✓			1	1			1	1						27
Voice Path				✓									1	1				25

\* Denotes the number of microphone inputs with a mic/line switch

# **JK Audio**

**QUALITY PRODUCTS FOR THE PROFESSIONAL BROADCAST INDUSTRY**

JK Audio, Inc. Sandwich, IL 60548 USA • Toll Free: 800-552-8346 • Tel: 815-786-2929 • Fax: 815-786-8502 • [www.jkaudio.com](http://www.jkaudio.com) • [info@jkaudio.com](mailto:info@jkaudio.com)

Printed in USA 4/08